

Micro Reach the peak

**Made for the
smallest and finest
surfaces. Range
1 - 6 Millimeter.**

ALBRECHT
GERMANY

Ideal for microtools.
Clamping range 1 - 6 mm.
Peripheral or internal cooling.
Significantly better dampening
in comparison to Shrink Chucks.
Slim shape $D1=13,5$ mm.
Perfect runout $\leq 3 \mu\text{m}$ $2,5xD$.
Up to 40.000 1/min ≤ 1 gmm.

For the finest surfaces even for
difficulty accessible areas.
Special coated collets.
Maintenance-free.
The Albrecht Micro.
None is more fine.



Micro Chuck-Extension

For extension of Precision Chucks.
Very slim design for operation areas which are not easy to access. High gripping torque and accuracy due to slow angle taper.



Micro Precision-Chuck-Extension with Cylindrical Shank.

Easy exchange of tools by setting of hex-key (included in delivery). Maintenance free. Sealed against coolant and contamination. Slow collet taper angle. Collet with special coating (see page 79). Clamping of tool shanks according to DIN 1835 A, B and DIN 6535 HB, HA. Tolerance of shank h6. System-Runout-Accuracy 8 µm at 2,5 x D.

Cylindrical shank 14 mm

1 – 6 mm

L1	Part.No.	Coolant	L2	D1	D2	AF	kg
100	310 1006 814 1	Central	29	13	14	13	0,16
150	310 2006 814 1	Central	29	13	14	13	0,10

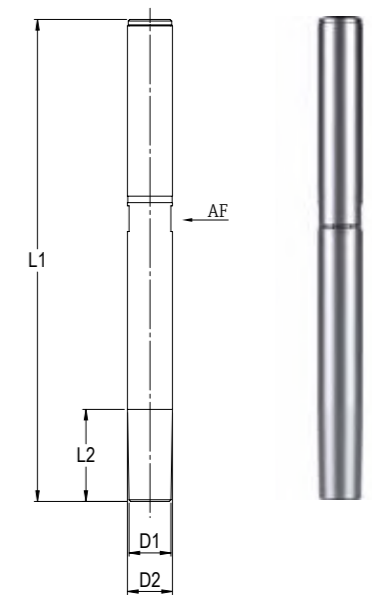

Cylindrical shank 20 mm

1 – 6 mm

L1	Part.No.	Coolant	L2	D1	D2	AF	kg
100	310 1006 820 1	Central	45	13	20	13	0,17
150	310 2006 820 1	Central	67	13	20	19	0,30

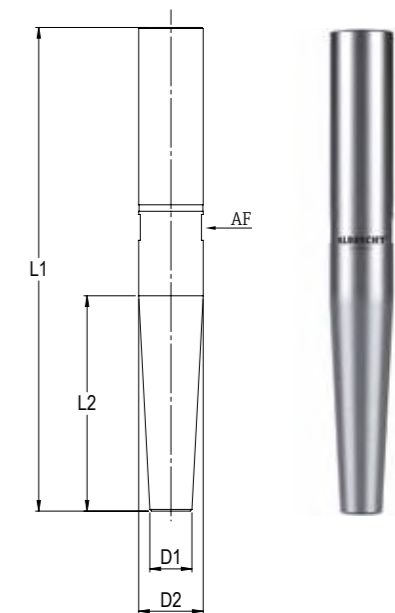

HSK

Micro Precision Chuck, ISO 12164 (DIN 69893)

Easy exchange of tools by setting of hex-key (included in delivery). Maintenance free. Sealed against coolant and contamination. Slow collet taper angle. Collet with special coating (see page 79). System-Runout-Accuracy 3 µm at 2,5 x D. Clamping of tool shanks according to DIN 1835 A, B and DIN 6535 HB, HA. Coolant tubes see page 99.

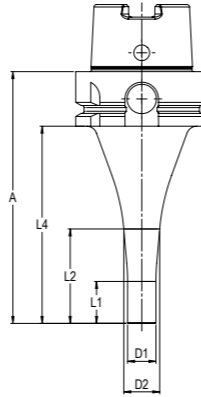

HSK 40-A 1 – 6 mm

A	Part.No.	Form	L1	L2	L4	D1	D2	Balanced	kg
75	310 1006 640 1	A	20	35	55	13,5	16	<1gmm	0,3

HSK 40-E									
A	Part.No.	Form	L1	L2	L4	D1	D2	Balanced	kg
75	310 10E6 640 1	E	20	35	55	13,5	16	<1gmm	0,3

HSK 50-A									
A	Part.No.	Form	L1	L2	L4	D1	D2	Balanced	kg
85	310 1006 650 1	A	20	34	59	13,5	16	<1gmm	0,5
120	310 2006 650 1	A	20	45	94	13,5	18	<1gmm	0,7

HSK 50-E									
A	Part.No.	Form	L1	L2	L4	D1	D2	Balanced	kg
85	310 10E6 650 1	E	20	40	59	13,5	17	<1gmm	0,5
120	310 20E6 650 1	E	20	45	94	13,5	18	<1gmm	0,7

HSK 63-A									
A	Part.No.	Form	L1	L2	L4	D1	D2	Balanced	kg
90	310 1006 663 1	A	20	30	64	13,5	15	20.000 G=2,5	0,8
120	310 2006 663 1	A	20	45	94	13,5	17	20.000 G=2,5	1,0
160	310 3006 663 1	A	20	70	134	13,5	22	20.000 G=2,5	1,2

HSK 63-F									
A	Part.No.	Form	L1	L2	L4	D1	D2	Balanced	kg
90	310 10F6 663 1	F	20	30	64	13,5	15	20.000 G=2,5	0,8
120	310 20F6 663 1	F	20	45	94	13,5	17	20.000 G=2,5	1,0

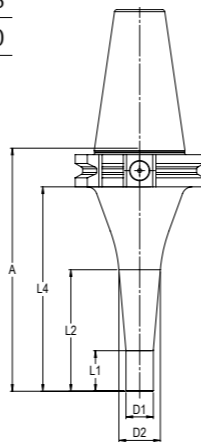

SK

Micro Precision Chuck, ISO 7388-1 (DIN 69871)

Easy exchange of tools by setting of hex-key (included in delivery). Maintenance free. Sealed against coolant and contamination. Slow collet taper angle. Collet with special coating (see page 79). System-Runout-Accuracy 3 µm at 2,5 x D. Clamping of tool shanks according to DIN 1835 A, B and DIN 6535 HB, HA.

SK 30 1 – 6 mm

A	Part.No.	Form	L1	L2	L4	D1	D2	Balanced	kg
75	310 2006 230 1	A/AD	20	32	56	13,5	16	<1gmm	0,5

SK 40									
A	Part.No.	Form	L1	L2	L4	D1	D2	Balanced	kg
90	310 1006 240 1	A/AD	20	38	71	13,5	17	20.000 G=2,5	1,0
120	310 2006 240 1	A/AD	20	60	101	13,5	21	20.000 G=2,5	1,2
160	310 3006 240 1	A/AD	20	75	141	13,5	23	20.000 G=2,5	1,2



MAS-BT

Micro Precision Chuck, ISO 7388-2 (JIS B 6339)

Easy exchange of tools by setting of hex-key (included in delivery). Maintenance free. Sealed against coolant and contamination. Slow collet taper angle. Collet with special coating (see page 79). System-Runout-Accuracy 3 µm at 2,5 x D. Clamping of tool shanks according to DIN 1835 A, B and DIN 6535 HB, HA.

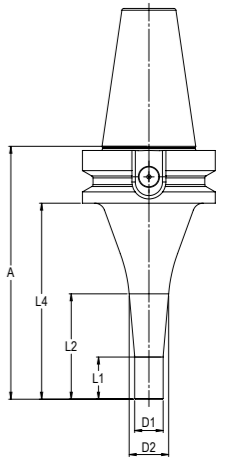

BT 30 1 – 6 mm

A	Part.No.	Form	L1	L2	L4	D1	D2	Balanced	kg
75	310 2006 430 1	A/AD	20	30	53	13,5	15	<1gmm	0,5

BT 40									
A	Part.No.	Form	L1	L2	L4	D1	D2	Balanced	kg
90	310 1006 440 1	A/AD	20	30	63	13,5	15	20.000 G=2,5	1,2
120	310 2006 440 1	A/AD	20	50	93	13,5	19	20.000 G=2,5	1,3
160	310 3006 440 1	A/AD	20	70	133	13,5	22	20.000 G=2,5	1,3



Polygon

Micro Precision Chuck, DIN ISO 26623-1

Easy exchange of tools by setting of hex-key (included in delivery). Maintenance free. Sealed against coolant and contamination. Slow collet taper angle. Collet with special coating (see page 79). System-Runout-Accuracy 3 µm at 2,5 x D. Clamping of tool shanks according to DIN 1835 A, B and DIN 6535 HB, HA.

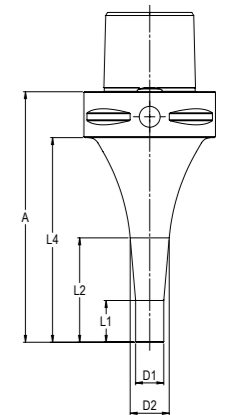

PSC 40 1 – 6 mm

A	Part.No.	Form	L1	L2	L4	D1	D2	Balanced	kg
75	310 1006 9C4 1	A	20	35	55	13,5	16	<1gmm	0,3

PSC 63									
A	Part.No.	Form	L1	L2	L4	D1	D2	Balanced	kg
90	310 1006 9C6 1	A	20	30	68	13,5	15	20.000 G=2,5	1,0
120	310 2006 9C6 1	A	20	50	98	13,5	19	20.000 G=2,5	1,1



Micro ER-Chuck

Increases the access of driven tooling.
High-speed balanced. Coolant directed to cutting tool.
Compatible with common ER-nuts except ER16.
Cutting tools supported over greater length,
more rigidity and dampening.



ER-Precision-Chuck, for Collet-Chucks according to DIN ISO 15488

Easy exchange of tools by using a hex-key (included in delivery).

Maintenance-free. Sealed against coolant and contamination. Slow collet taper angle.

Collet with special coating (see page 79). System-Runout-Accuracy 3 µm at 2,5 x D.

Clamping of tool shanks according to DIN 1835 A, B and DIN 6535 HB, HA.

ER 16 1 – 6 mm

A	Part.No.	L1	D1	Balanced	kg
35	310 1006 316 1*	35	13,5	by design	0,1

Special clamping nuts

Typ	Part.No.	D	L	Thread	Key
standard	138 0310 316 0	28	17,5	M22x1,5	SW 25
mini	138 0311 316 0	22	17	M19x1	E16 Zeta
internal	138 0312 316 0	M24x1	6,5	-	E16 Zeta

*only use in combination with special clamping nut, based on DIN 6499

ER 20 1 – 6 mm

A	Part.No.	L1	D1	Balanced	kg
28	310 1006 320 1	28	13,5	by design	0,1
35	310 2006 320 1	35	13,5	by design	0,1

ER 25 1 – 6 mm

A	Part.No.	L1	D1	Balanced	kg
25	310 1006 325 1	12	13,5	by design	0,1
40	310 2006 325 1	15	13,5	by design	0,1
50	310 3006 325 1	20	13,5	by design	0,1

ER 32 1 – 6 mm

A	Part.No.	L1	D1	Balanced	kg
25	310 1006 332 1	12	13,5	by design	0,2
40	310 2006 332 1	15	13,5	by design	0,2
50	310 3006 332 1	20	13,5	by design	0,2

Precision-Chuck, for Varia VX quick-change systems

One-piece for tightening from behind

VARIA VX3 1 – 6 mm

A	Part.No.	L1	L2	D1	D2	Balanced	kg
36	310 0006 VX3 1	24		13,5		by design	0,3
50	310 1006 VX3 1	12	37	13,5	18	by design	0,5

VARIA VX4 1 – 6 mm

A	Part.No.	L1	L2	D1	D2	Balanced	kg
70	310 1006 VX4 1	15	55	13,5	20	by design	1,0



Collets and Accessories



Collets Peripheral Coolant. Additional cooling and rinsing effect. Increases the safety of processing. Special Coating. Maintenance free. Clamping of tool shanks corresponding to DIN 1835A, B and DIN 6335 HB, HA.

1 – 6 mm

D	Part.No.	Coolant	kg
1,0	136 0601 000 0	Periphery	0,02
2,0	136 0602 000 0	Periphery	0,02
2,5	136 0602 500 0	Periphery	0,02
2,8	136 0602 800 0	Periphery	0,02
3,0	136 0603 000 0	Periphery	0,02
3,5	136 0603 500 0	Periphery	0,02
4,0	136 0604 000 0	Periphery	0,02
4,5	136 0604 500 0	Periphery	0,02
5,0	136 0605 000 0	Periphery	0,02
6,0	136 0606 000 0	Periphery	0,02

special size and inch diameter on request

Collets Internal Coolant. 100% leak proof up to 100 bar coolant pressure. Special Coating. Maintenance free. Clamping of tool shanks corresponding to DIN 1835A, B and DIN 6335 HB, HA.

1 – 6 mm

D	Part.No.	Coolant	kg
1,0	136 0601 000 T	Central	0,02
2,0	136 0602 000 T	Central	0,02
2,5	136 0602 500 T	Central	0,02
2,8	136 0602 800 T	Central	0,02
3,0	136 0603 000 T	Central	0,02
3,5	136 0603 500 T	Central	0,02
4,0	136 0604 000 T	Central	0,02
4,5	136 0604 500 T	Central	0,02
5,0	136 0605 000 T	Central	0,02
6,0	136 0606 000 T	Central	0,02

special size and inch diameter on request

Torque Key	Blade lenght	Part.No.
3,0 - 5,4 Nm	113	139 0005 900 0
3,0 - 5,4 Nm	160	139 0005 900 2*

* for Part.No.: 310 3006 240 1 and 310 3006 440 1

Taper Wiper	Part.No.
for Micro	139 0000 GRO 0
Replacement papers, 25 pcs.	139 0000 GRO 2

Pull Stud	Part.No.	Thread	through-hole	Angle	Neck- Ø	kg
SK30	138 0004 230 0	M12	Ø4	15°	9	0,03
BT30	138 0004 430 0	M12	Ø4	45°	8	0,04
BT40	138 0004 440 0	M16	Ø4	45°	10	0,04

based on DIN



XXL Chuck Extension

The extension for all Albrecht chucks. Slim and long. The solution for all difficult to access processing zones. Safe transmission of clamping force and torque. For drilling, tapping, sinking, etc. Internal coolant supply. Run-out < 0.05 mm. Drilled through for coolant supply. Can be shortened individually.



Cylindrical shank 12 mm 3 – 6 mm

L	Part.No.	Coolant	D	kg
150	340 0615 812 0	Central	12	0,10
250	340 0625 812 0	Central	12	0,17
355	340 0635 812 0	Central	12	0,24

Cylindrical shank 16 mm 6 – 8 mm

L	Part.No.	Coolant	D	kg
150	340 0815 816 0	Central	16	0,15
250	340 0825 816 0	Central	16	0,28
350	340 0835 816 0	Central	16	0,40

Cylindrical shank 18 mm 8 – 10 mm

L	Part.No.	Coolant	D	kg
150	340 1015 818 0	Central	18	0,19
250	340 1025 818 0	Central	18	0,36
350	340 1035 818 0	Central	18	0,53

Cylindrical shank 20 mm 11 – 12 mm

L	Part.No.	Coolant	D	kg
150	340 1215 820 0	Central	20	0,27
250	340 1225 820 0	Central	20	0,50
350	340 1235 820 0	Central	20	0,73

Collets

For Cylindrical shank 12 mm 3 – 6 mm

D	Part.No.	AF	kg
3	146 1203 000 0	9	0,02
4	146 1204 000 0	9	0,02
5	146 1205 000 0	9	0,02
6	146 1206 000 0	9	0,02

For Cylindrical shank 16 mm 6 – 8 mm

D	Part.No.	AF	kg
6	146 1606 000 0	12	0,02
7	146 1607 000 0	12	0,02
8	146 1608 000 0	12	0,02

For Cylindrical shank 18 mm 8 – 10 mm

D	Part.No.	AF	kg
8	146 1808 000 0	14	0,04
9	146 1809 000 0	14	0,04
10	146 1810 000 0	14	0,04

For Cylindrical shank 20 mm 11 – 12 mm

D	Part.No.	AF	kg
11	146 2011 000 0	16	0,05
12	146 2012 000 0	16	0,05

special size and sealed for tools with internal coolant supply on request

Accessories

XXL-Wrench

For Cylindrical shank	Part.No.
10-50 Nm for Adapter 1/2"	149 0000 934 0*

Adapter 1/2"

for Cylindrical shank	Part.No.	AF
12	149 0001 934 1	9
16	149 0001 934 2	12
18	149 0001 934 3	14
20	149 0001 934 5	16

*only to use in combination with XXL-Extensions



Mountingsystem

flexible, vertical/horizontal, locked



Mounting System Base Unit	Part.No.
	730 1000 000 0



Adapters	Part.No.
ISO 7388-1 + ISO7388-2	
SK30 + BT30	730 1000 230 0
SK40 + BT40 + CAT40	730 1000 240 0
SK50 + BT50 + CAT50	730 1000 250 0
DIN 69893	
HSK50 Form A+C	730 1000 650 0
HSK63 Form A+C	730 1000 663 0
HSK80 Form A+C	730 1000 680 0
HSK100 Form A+C	730 1000 610 0
ISO 26623-1	
PSC50	730 1000 9C5 0
PSC63	730 1000 9C6 0
PSC80	730 1000 9C8 0

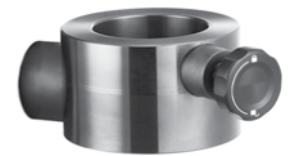

Accessories HSK

Coolant tubes DIN 69893 (HSK)	Part.No
Coolant tubes HSK-A50	139 0002 650 0
Coolant tubes HSK-A63	139 0002 663 0
Coolant tubes HSK-A80	139 0002 680 0
Coolant tubes HSK-A100	139 0002 610 0



Key with T-handle	Part.No
for coolant tubes HSK-A50	139 0020 650 0
for coolant tubes HSK-A63	139 0020 663 0
for coolant tubes HSK-A80	139 0020 680 0
for coolant tubes HSK-A100	139 0020 610 0



Handling Micro

The Albrecht Micro Chuck is a high precision toolholder with an integrated clamping screw. Its unique design provides a high run-out accuracy as well as a positive dampening feature for clamping of tools with cylindrical shafts for machining (milling, finish-milling, HSC-milling, drilling, tapping, reaming). The Micro uses a special collet to clamp the cutting tool and is operated by a hex key from the behind.



Cleaning, insert the Collet

Before each use, clean the tool shaft, inner-cone of Micro and collet. To completely remove grease and dirt particles use a lint-free cloth and a cleaner. Attention, do not work with compressed air during the cleaning process, as otherwise dissolved dirt particles can get into parts of the gearbox.



For maximum clamping forces, the bore, the tool shank, the cone of the clamping sleeve and the inner cone chuck must be degreased each time the tool is changed.



Insert the cleaned and undamaged tool shank into the clamping sleeve, observing the minimum clamping depth, see page 103. Screw the clamping sleeve with tool into the chuck manually until the clamping sleeve touches the cone.



Clamping

Put in the hex key as far as possible. Hex tool surface is to be inspected for damages! The chucking procedure start with inserting the hex key from behind through the chuck and rotating the hex key clockwise. Max. clamping torque see mark on the Micro. Use only the original Albrecht clamping key which is included or the torque key, 3,0 - 5,4 Nm, part.no 139 0005 900 0, see page 79.



Releasing

Open the Micro by turning the hex key counter-clockwise. Note: when opening the Micro, you must overcome two resistance points. First, you will overcome the friction torque and then the collet is loosened. Then open until the tool can be taken out, or rather the collet can be unscrewed manually.

Clamping depth
depending on clamping diameter

Ø	t min	t max
2-4	18	36
5	18	28
6	26	36

Min. Clamping depth = t min
Max. Clamping depth = t max

Max. rpm see product-marking
Max. operation temperature: 110°C
Max. coolant pressure: 100 bar

Balancing grade

Each Albrecht Micro-Chuck is fine-balanced without collet and tool according to the laser marking. Higher balancing quality and rpm on request. The use of shanks with slots influences the balancing grade and run-out accuracy of the whole system.

Maintenance

The Micro-Chuck is maintenance free over his lifetime. Clean chuck (especially the inner cone) and collet including thread after usage with a solvent base cleaner. According to contamination the cleaning cycles have to be adjusted. After cleaning, apply a thin coat of anticorrosive.

Repairs

In order to guarantee the precision of the tool, any chuck in need of repair has to be sent to the manufacturer or to an authorized national agent only. We recommend checking the Micro-Chuck and the collet for run-out deviations and gripping torque periodic, especially after a tool break or crash.