

2025

ALBRECHT
Germany

ALBRECHT
Germany

Better
Albrecht

ALBRECHT
Germany



Albrecht.

**We lead
tools
to max
performance.**

Welcome.
And thank you very much.



Martin Schmieder
Managing & Sales Director



Joel Ammersdörfer
Director Research & Development



Kitae Kim
Director Albrecht Korea & Asia

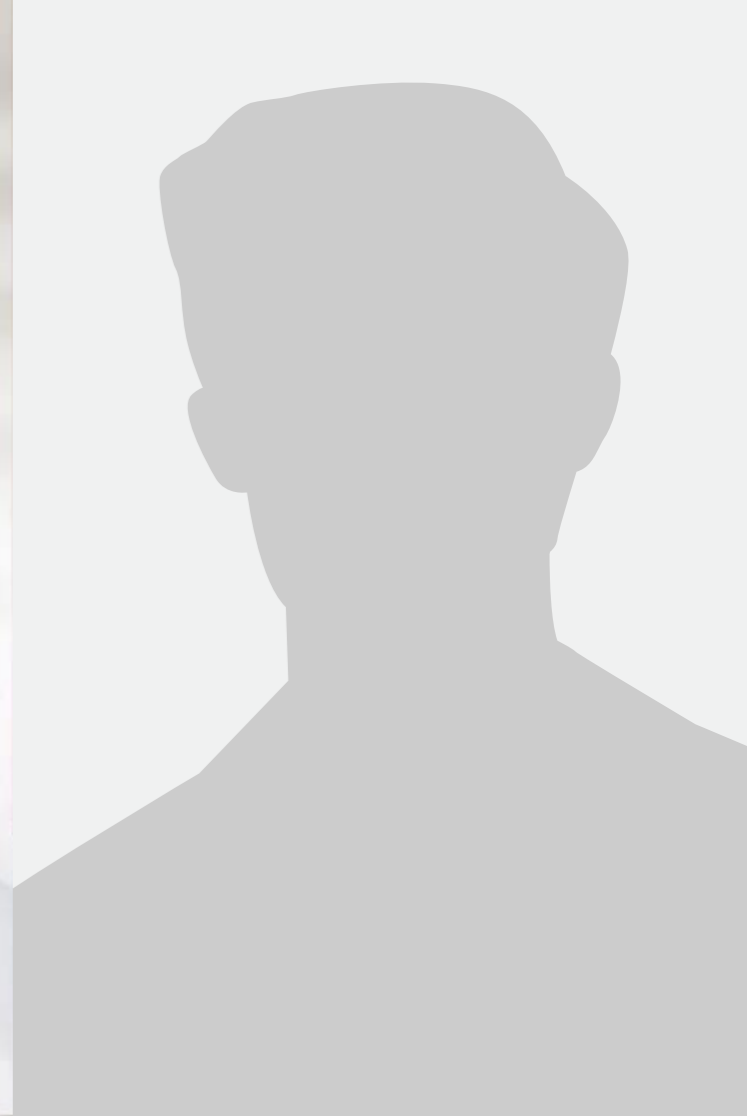

Marc Heinrich
Director Export



Sebastian Kögl
Area Sales Manager Germany South,
AT & CH



Marco Requardt
Area Sales Manager Germany North
& International



Martin Stark
Technical Sales Manager

An APC from Albrecht

**At present APC is
the best performing
chuck worldwide
in the area of speed,
tool life and safety.**

HSK50, HSK63, HSK80, HSK100, HSK125, SK30, SK40,
SK50, BT30, BT40, BT50, PSC50, PSC63, PSC80,
BT30, BT40 and BT50 with additional dual contact.



ALBRECHT
Germany

The Slim5

The power for 5-axis operation. Achieve anything safely and with speed.

Clamping range 2 - 14 mm, 2 - 20 mm or 16 - 32 mm.

Slim Front, gage length = 120 - 178 mm (HSK63).

No tool pull-out due to pin-lock collets.

Extremely slim tapered, 4,5°.

High accuracy and dampening.

Optimal power transmission.

100% leak proof and up to 100 bars also with internal coolant supply for the tools.

Ultimate additional cooling and rinsing effect due to peripheral cooling.



Winner in Speed.

1. Albrecht APC 400 mm

2. Hydraulic 320 mm

4. Shrink Fit 280 mm

3. Weldon 300 mm

00:23

On this photo finish the production speed of 4 chuck technologies is being compared. The machine, the milling cutter D=16 mm

and the material are identical for all 4 milling operations. We call out to any sceptic: come to the race! Albrecht APC.

Winner in Lifetime.



Weldon
One-sided
wear
Out!

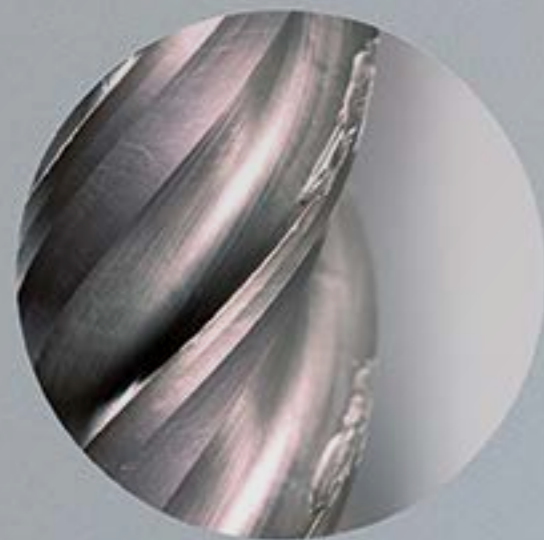

Shrink Fit
Big
nicks
Stop!

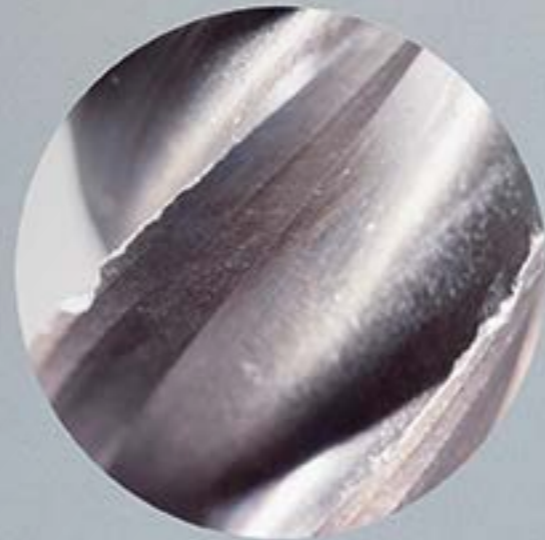

Hydraulic
Micro
nicks
Limited!

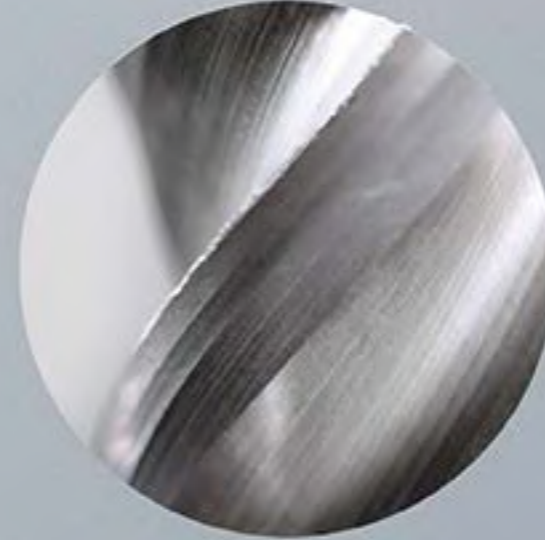

Albrecht APC
Minimal
rounding
Good
Continue!

This comparison shows the influence the chuck has on the life of your cutting tool. The test milling cutter is a 4-blades tool, D=16 mm, with identical material, machine and parameters. The tool life advantage in the Albrecht APC chuck can clearly be attributed to the excellent vibration dampening and highly precise accuracy of this precision chuck. We ask you to value your economic advantages yourself.

Winner in Safety.

100%



Weldon Holds

The most common solution. The mill is fixed with a side lock screw. Solid fixation. No dampening. Run-out not so good.

Hydraulic Possible pull-out

The mill is held by an inner membrane. This “soft” technology might enable the mill “to be levered out” especially by lateral forces.

Shrink Fit Possible pull-out

Clamping very rigid. Thus, vibrations might loosen the mill from the chuck. The clamping torque is dependent on the tolerances of tool shaft.

Albrecht APC Holds

Strong clamping force due to the assemblage of collet and taper. Available also with Pin-Lock engaged to Weldon slot which acts as an additional safe-guard for the mill. This we guarantee!

These wins have reasons.

1. The world's only Milling Chuck with 1:16 worm gear.

The only way how 100% holding force gets to the cutting tool.

2. Highest rigidity thanks to design and body.



3. The worm gear with 3 tons traction force and the collet with a slow-taper angle of 1,25° do guide the tool perfectly through trochoidal-, dry- and hard-machining operations up to 110° C.

4. Ideal dampening. The collet-cone assemblage absorbs virtually all vibrations. Measuring portfolio from Institut for Produktionsmanagement and University of Technology Hamburg see page 104–105

HSK

Precision Chuck APC, DIN 69893 (ISO 12164) with fine balancing holes 6xM6

Easy exchange of tools by setting of hex-key (see page 59). Maintenance free.

Sealed against coolant and contamination. Slow collet taper angle. Collet

with special coating (see page 44–57). System-Runout-Accuracy 3 µm at 2,5 x D.

Clamping of tool shanks according to DIN 1835 A, B and DIN 6535 HB, HA.

Balancing screws see page 96. Coolant tubes see page 99.

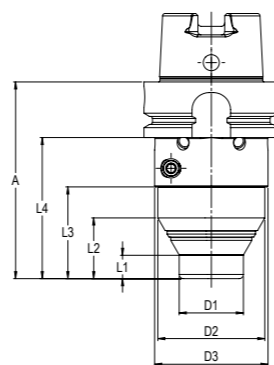

APC 14

HSK50 A 2 – 14 mm

A	Part.No.	Form	L1	L2	L3	L4	D1	D2	D3	Balanced	kg
101	300 014Z 650 0	A	11	28	43	75	30	50	53	20.000 G=2,5	1,1
187	300 214Z 650 0	A	85	103	142	161	30	50	53	20.000 G=2,5	1,9

HSK63 A 2 – 14 mm

A	Part.No.	Form	L1	L2	L3	L4	D1	D2	D3	Balanced	kg
92	300 014Z 663 0	A	11	28	43	66	30	50	53	20.000 G=2,5	1,3
120	300 614Z 663 0	A	39	56	71	94	30	50	53	20.000 G=2,5	1,4
142	300 514Z 663 0	A	61	78	93	116	30	50	53	20.000 G=2,5	1,5
178	300 214Z 663 0	A	85	103	129	152	30	50	53	20.000 G=2,5	1,9

APC 20

HSK50 A 2 – 20 mm

A	Part.No.	Form	L1	L2	L3	L4	D1	D2	D3	Balanced	kg
101	300 120Z 650 0	A	20	31	56	75	40	53		20.000 G=2,5	1,1

HSK63 A 2 – 20 mm

A	Part.No.	Form	L1	L2	L3	L4	D1	D2	D3	Balanced	kg
92	300 120Z 663 0	A	20	31		66	40	53		20.000 G=2,5	1,3
120	300 620Z 663 0	A	48	56	71	94	40	50	53	20.000 G=2,5	1,6
142	300 520Z 663 0	A	69	81		116	40	53		20.000 G=2,5	1,7
178	300 220Z 663 0	A	94	105		152	40	53		20.000 G=2,5	2,0

HSK63 F 2 – 20 mm

A	Part.No.	Form	L1	L2	L3	L4	D1	D2	D3	Balanced	kg
92	300 120ZF 663 0*	F	20	31		66	40	53		20.000 G=2,5	1,3

HSK63/80 A 2 – 20 mm

A	Part.No.	Form	L1	L2	L3	L4	D1	D2	D3	Balanced	kg
92	300 020Z 668 0	A	20	31		66	40	53		20.000 G=2,5	1,7

*delivery includes sealing plug in HSK

other lengths see page 41

APC 20

HSK80 A 2 – 20 mm

A	Part.No.	Form	L1	L2	L3	L4	D1	D2	D3	Balanced	kg
98	300 120Z 680 0	A	18	38		72	40	63		20.000 G=2,5	1,8

HSK80 FM 2 – 20 mm

A	Part.No.	Form	L1	L2	L3	L4	D1	D2	D3	Balanced	kg
100	300 020F 68M 0**	FM	20	38	43	74	40	63	70	20.000 G=2,5	2,4

HSK100 A 2 – 20 mm

A	Part.No.	Form	L1	L2	L3	L4	D1	D2	D3	Balanced	kg
100	300 020Z 610 0	A	18	38	43	71	40	63	70	20.000 G=2,5	3,8
150	300 820Z 610 0	A	48	68	93	121	40	63	70	20.000 G=2,5	4,2
186	300 920Z 610 0	A	84	104	129	157	40	63	70	20.000 G=2,5	4,5

** Special type with 2x pin Ø5, pitch circle-Ø58

other lengths see page 41

APC 25

HSK63 A 16 – 32 mm

A	Part.No.	Form	L1	L2	L3	L4	D1	D2	D3	Balanced	kg
132	300 025Z 663 0	A	14		83	106	53	63	53	20.000 G=2,5	2,2

HSK80 A 16 – 32 mm

A	Part.No.	Form	L1	L2	L3	L4	D1	D2	D3	Balanced	kg
137	300 025Z 680 0	A	14			111	53	63		20.000 G=2,5	2,5

HSK100 A 16 – 32 mm

A	Part.No.	Form	L1	L2	L3	L4	D1	D2	D3	Balanced	kg
139	300 025Z 610 0	A	15			110	53	70		20.000 G=2,5	4,7

HSK125 A 16 – 32 mm

A	Part.No.	Form	L1	L2	L3	L4	D1	D2	D3	Balanced	kg
145	300 025Z 612 0	A	15			116	53	70		20.000 G=2,5	6,0

other lengths see page 42

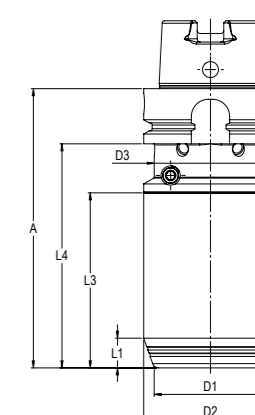

HSK Slim5

Precision Chuck APC, DIN 69893 (ISO 12164) with fine balancing holes 6xM6

Slim line with 4,5° especially for 5-axis operations. Easy exchange of tools by setting of hex-key (see page 59). Maintenance free. Sealed against coolant and contamination.

Slow collet taper angle. Collet with special coating (see page 44–57).

System-Runout-Accuracy 3 µm at 2,5 x D.

Clamping of tool shanks according to DIN 1835 A, B and DIN 6535 HB, HA.

Balancing screws see page 96. Coolant tubes see page 99.

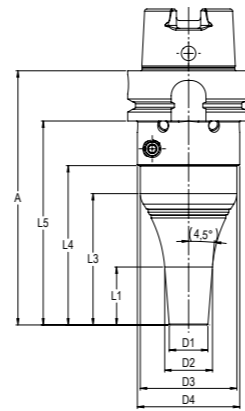

APC 10 Slim5

HSK63 A 2 – 10 mm

A	Part.No.	Form	L1	L2	L3	L4	L5	D1	D2	D3	D4	Balanced	kg
132	300 410Z 663 1	A	30	68	83	106	20	25	50	53	20.000	G=2,5	1,5
168	300 410Z 663 2	A	70	103	119	142	20	31	50	53	20.000	G=2,5	1,6



APC 14 Slim5

HSK63 A 2 – 14 mm

A	Part.No.	Form	L1	L2	L3	L4	L5	D1	D2	D3	D4	Balanced	kg	
120	300 414Z 663 0	A	38	56	71	94	24	30	50	53	20.000	G=2,5	1,4	
142	300 414Z 663 1	A	38	61	78	93	116	24	30	50	53	20.000	G=2,5	1,5
178	300 414Z 663 2	A	38	85	103	129	152	24	30	50	53	20.000	G=2,5	1,8

weitere Längen siehe Seite 43

APC 14 Slim5

HSK100 A 2 – 14 mm

A	Part.No.	Form	L1	L2	L3	L4	L5	D1	D2	D3	D4	Balanced	kg	
128	300 414Z 610 0	A	38	56	71	99	24	30	50	70	20.000	G=2,5	3,2	
150	300 414Z 610 1	A	38	61	78	93	121	24	30	50	70	20.000	G=2,5	3,3
186	300 414Z 610 2	A	38	85	103	129	157	24	30	50	70	20.000	G=2,5	3,6

other lengths see page 43



APC 20 Slim5

HSK63 A 2 – 20 mm

A	Part.No.	Form	L1	L2	L3	L4	L5	D1	D2	D3	D4	Balanced	kg	
120	300 420Z 663 0	A	44	54	71	94	32	39	50	53	20.000	G=2,5	1,5	
142	300 420Z 663 1	A	50	69	78	93	116	32	40	50	53	20.000	G=2,5	1,6
178	300 420Z 663 2	A	50	94	103	129	152	32	40	50	53	20.000	G=2,5	2,1

other lengths see page 43

APC 20 Slim5

HSK100 A 2 – 20 mm

A	Part.No.	Form	L1	L2	L3	L4	L5	D1	D2	D3	D4	Balanced	kg	
128	300 420Z 610 0	A	44	61	71	99	32	39	63	70	20.000	G=2,5	3,4	
150	300 420Z 610 1	A	50	69	89	93	121	32	40	63	70	20.000	G=2,5	3,5
186	300 420Z 610 2	A	50	94	114	129	157	32	40	63	70	20.000	G=2,5	4,0

other lengths see page 43

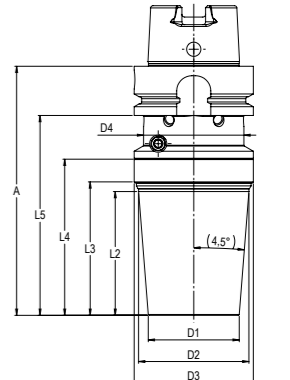
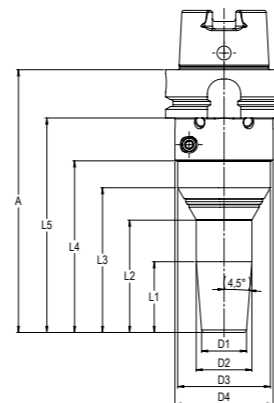

APC 25 Slim5

HSK63 A 16 – 32 mm

A	Part.No.	Form	L1	L2	L3	L4	L5	D1	D2	D3	D4	Balanced	kg
132	300 425Z 663 0	A	66	70	83	106	48	58	63	53	20.000	G=2,5	1,9

APC 25 Slim5

HSK100 A 16 – 32 mm

A	Part.No.	Form	L1	L2	L3	L4	L5	D1	D2	D3	D4	Balanced	kg
139	300 425Z 610 0	A	66	70	83	110	48	58	63	70	20.000	G=2,5	3,7



SK

Precision Chuck APC, ISO 7388-1 (DIN 69871)

Easy exchange of tools by setting of hex-key (see page 59). Maintenance free. Sealed against coolant and contamination. Slow collet taper angle. Collet with special coating (see page 44 –57). System-Runout-Accuracy 3 µm at 2,5 x D. Clamping of tool shanks according to DIN 1835 A, B and DIN 6535 HB, HA.

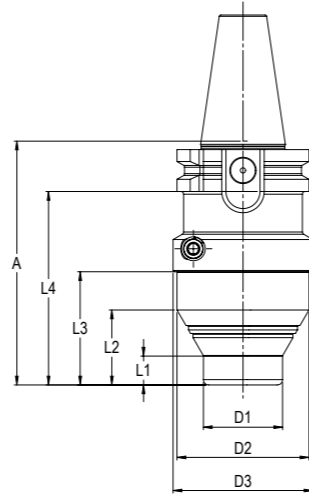

APC 14

SK30 2 – 14 mm

A	Part.No.	Form	L1	L2	L3	L4	D1	D2	D3	Balanced	kg
92	300 014Z 230 0	A/AD	11	28	43	73	30	50	53	20.000 G=2,5	1,0
142	300 514Z 230 0	A/AD	61	78	93	123	30	50	53	20.000 G=2,5	1,4



SK40 2 – 14 mm

A	Part.No.	Form	L1	L2	L3	L4	D1	D2	D3	Balanced	kg
63	300 014Z 240 0	A/AD	11	28		43	30	50		20.000 G=2,5	1,1
91	300 614Z 240 0	A/AD	39	56		71	30	50		20.000 G=2,5	1,2
112	300 514Z 240 0	A/AD	61	78		93	30	50		20.000 G=2,5	1,3
149	300 914Z 240 0	A/AD	85	103		129	30	50		20.000 G=2,5	1,7



APC 20

SK30 2 – 20 mm

A	Part.No.	Form	L1	L2	L3	L4	D1	D2	D3	Balanced	kg
92	300 120Z 230 0	A/AD	20	28		73	40	53		20.000 G=2,5	1,1



SK40 2 – 20 mm

A	Part.No.	Form	L1	L2	L3	L4	D1	D2	D3	Balanced	kg
63	300 020Z 240 0	A/AD	20	28		43	40	50		20.000 G=2,5	1,1
91	300 620Z 240 0	A/AD	48	56		71	40	50		20.000 G=2,5	1,4
112	300 520Z 240 0	A/AD	69	78		93	40	50		20.000 G=2,5	1,6
149	300 920Z 240 0	A/AD	94	103		129	40	50		20.000 G=2,5	1,9



APC 20

SK50 2 – 20 mm

A	Part.No.	Form	L1	L2	L3	L4	D1	D2	D3	Balanced	kg
62	300 020Z 250 0	A/AD	18	38		43	40	63		20.000 G=2,5	3,1
112	300 820Z 250 0	A/AD	48	68		93	40	63		20.000 G=2,5	3,5
149	300 920Z 250 0	A/AD	84	104		129	40	63		20.000 G=2,5	3,8

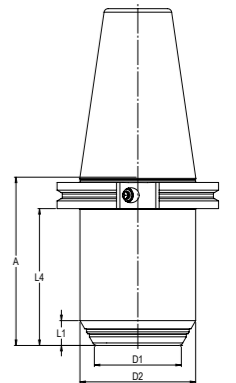

APC 25

SK40 16 – 32 mm

A	Part.No.	Form	L1	L2	L3	L4	D1	D2	D3	Balanced	kg
102	300 025Z 240 0	A/AD	14			83	53	63*		20.000 G=2,5	2,1

* without Safety Zone, with Safety Zone see Part.No. 300 025Z 240 1 (on request)



SK50 16 – 32 mm

A	Part.No.	Form	L1	L2	L3	L4	D1	D2	D3	Balanced	kg
102	300 025Z 250 0	A/AD	15			83	53	70		20.000 G=2,5	4,3

SK Slim5

Precision Chuck APC, ISO 7388-1 (DIN 69871)

Slim line with 4,5° especially for 5-axis operations. Easy exchange of tools by setting of hex-key (see page 59). Maintenance free. Sealed against coolant and contamination.

Slow collet taper angle. Collet with special coating (see page 44–57).

System-Runout-Accuracy 3 µm at 2,5 x D.

Clamping of tool shanks according to DIN 1835 A, B and DIN 6535 HB, HA.

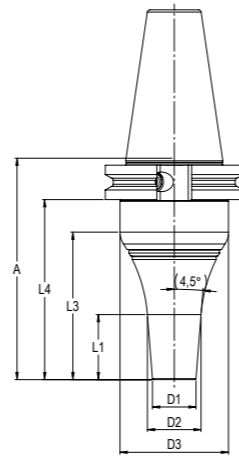

APC 10 Slim5

SK40 2–10 mm

A	Part.No.	Form	L1	L2	L3	L4	D1	D2	D3	Balanced	kg
102	300 410Z 240 1	A/AD	30		68	83	20	25	50	20.000 G=2,5	1,3
139	300 410Z 240 2	A/AD	70		103	119	20	31	50	20.000 G=2,5	1,5

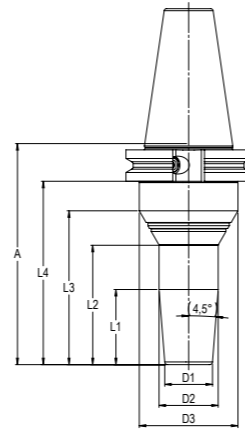

APC 14 Slim5

SK40 2–14 mm

A	Part.No.	Form	L1	L2	L3	L4	D1	D2	D3	Balanced	kg
91	300 414Z 240 0	A/AD		38	56	71	24	30	50	20.000 G=2,5	1,2
112	300 414Z 240 1	A/AD		38	61	78	24	30	50	20.000 G=2,5	1,3
149	300 414Z 240 2	A/AD		38	85	103	24	30	50	20.000 G=2,5	1,6



APC 14 Slim5

SK50 2–14 mm

A	Part.No.	Form	L1	L2	L3	L4	D1	D2	D3	Balanced	kg
91	300 414Z 250 0	A/AD		38	56	71	24	30	50	20.000 G=2,5	3,0
112	300 414Z 250 1	A/AD		38	61	78	24	30	50	20.000 G=2,5	3,1
149	300 414Z 250 2	A/AD		38	85	103	24	30	50	20.000 G=2,5	3,5



APC 20 Slim5

SK40 2–20 mm

A	Part.No.	Form	L1	L2	L3	L4	D1	D2	D3	Balanced	kg
91	300 420Z 240 0	A/AD		44	54	71	32	39	50	20.000 G=2,5	1,3
112	300 420Z 240 1	A/AD		50	69	78	32	40	50	20.000 G=2,5	1,4
149	300 420Z 240 2	A/AD		50	94	103	32	40	50	20.000 G=2,5	1,9



APC 20 Slim5

SK50 2–20 mm

A	Part.No.	Form	L1	L2	L3	L4	D1	D2	D3	Balanced	kg
91	300 420Z 250 0	A/AD		44	61	71	32	39	63	20.000 G=2,5	3,2
112	300 420Z 250 1	A/AD		50	69	89	32	40	63	20.000 G=2,5	3,4
149	300 420Z 250 2	A/AD		50	94	114	32	40	63	20.000 G=2,5	3,8

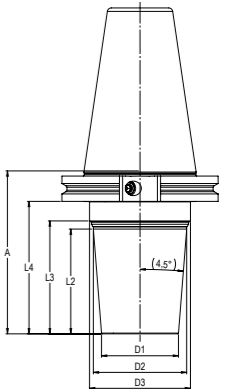

APC 25 Slim5

SK40 16–32 mm

A	Part.No.	Form	L1	L2	L3	L4	D1	D2	D3	Balanced	kg
102	300 425Z 240 0	A/AD		66	70		48	58	63	20.000 G=2,5	1,7



APC 25 Slim5

SK50 16–32 mm

A	Part.No.	Form	L1	L2	L3	L4	D1	D2	D3	Balanced	kg
102	300 425Z 250 0	A/AD		66	70	83	48	58	63	20.000 G=2,5	3,9



MAS-BT

Precision Chuck APC, ISO 7388-2 (JIS B 6339)

Easy exchange of tools by setting of hex-key (see page 59).
 Maintenance free. Sealed against coolant and contamination.
 Slow collet taper angle. Collet with special coating (see page 44–57).
 System-Runout-Accuracy 3 µm at 2,5 x D. Clamping of tool shanks according to DIN 1835 A, B and DIN 6535 HB, HA.

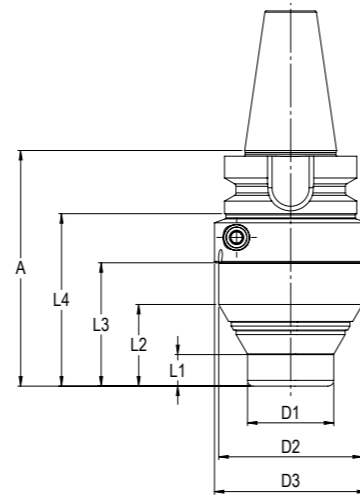

APC 14

BT30 2 – 14 mm

A	Part.No.	Form	L1	L2	L3	L4	D1	D2	D3	Balanced	kg
82	300 014Z 430 0	A/AD	11	28	43	60	30	50	53	20.000 G=2,5	0,9



BT40 2 – 14 mm

A	Part.No.	Form	L1	L2	L3	L4	D1	D2	D3	Balanced	kg
70	300 014Z 440 0	A/AD	11	28	43	60	30	50	53	20.000 G=2,5	1,2
98	300 614Z 440 0	A/AD	39	56	71	71	30	50	53	20.000 G=2,5	1,4
120	300 514Z 440 0	A/AD	61	78	93	93	30	50	53	20.000 G=2,5	1,5
156	300 914Z 440 0	A/AD	85	103	129	129	30	50	53	20.000 G=2,5	2,0



APC 20

BT30 2 – 20 mm

A	Part.No.	Form	L1	L2	L3	L4	D1	D2	D3	Balanced	kg
82	300 120Z 430 0	A/AD	20	31	43	60	40	53	53	20.000 G=2,5	0,9



BT40 2 – 20 mm

A	Part.No.	Form	L1	L2	L3	L4	D1	D2	D3	Balanced	kg
70	300 020Z 440 0	A/AD	18	38	43	60	40	63	63	20.000 G=2,5	1,4
99	300 620Z 440 0	A/AD	35	55	71	71	40	63	63	20.000 G=2,5	1,7
120	300 520Z 440 0	A/AD	48	68	93	93	40	63	63	20.000 G=2,5	1,8
156	300 920Z 440 0	A/AD	84	104	129	129	40	63	63	20.000 G=2,5	2,1



APC 20

BT50 2 – 20 mm

A	Part.No.	Form	L1	L2	L3	L4	D1	D2	D3	Balanced	kg
81	300 020Z 450 0	A/AD	18	38	43	60	40	63	63	20.000 G=2,5	4,2
131	300 820Z 450 0	A/AD	48	68	93	93	40	63	63	20.000 G=2,5	4,6
167	300 920Z 450 0	A/AD	84	104	129	129	40	63	63	20.000 G=2,5	4,9

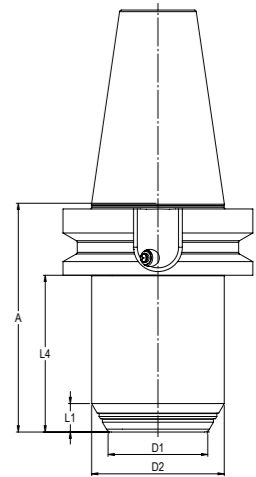

APC 25

BT40 16 – 32 mm

A	Part.No.	Form	L1	L2	L3	L4	D1	D2	D3	Balanced	kg
110	300 025Z 440 0	A/AD	14			83	53	63	63	20.000 G=2,5	2,4



BT50 16 – 32 mm

A	Part.No.	Form	L1	L2	L3	L4	D1	D2	D3	Balanced	kg
121	300 025Z 450 0	A/AD	15			83	53	70	70	20.000 G=2,5	4,6

MAS-BT Slim5

Precision Chuck APC, ISO 7388-2 (JIS B 6339)

Slim line with 4,5° especially for 5-axis operations. Easy exchange of tools by setting of hex-key (see page 59). Maintenance free. Sealed against coolant and contamination.

Slow collet taper angle. Collet with special coating (see page 44–57).

System-Runout-Accuracy 3 µm at 2,5 x D.

Clamping of tool shanks according to DIN 1835 A, B and DIN 6535 HB, HA.

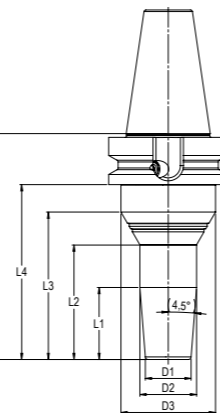
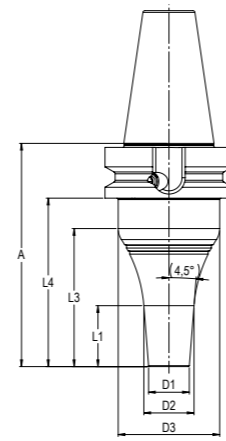

APC 10 Slim5

BT40 2–10 mm

A	Part.No.	Form	L1	L2	L3	L4	D1	D2	D3	Balanced	kg
110	300 410Z 440 1	A/AD	30		68	83	20	25	50	20.000 G=2,5	1,5
146	300 410Z 440 2	A/AD	70		103	119	20	31	50	20.000 G=2,5	1,6

APC 14 Slim5

BT40 2–14 mm

A	Part.No.	Form	L1	L2	L3	L4	D1	D2	D3	Balanced	kg
98	300 414Z 440 0	A/AD		38	56	71	24	30	50	20.000 G=2,5	1,4
120	300 414Z 440 1	A/AD		38	61	78	24	30	50	20.000 G=2,5	1,5
157	300 414Z 440 2	A/AD		38	85	103	24	30	50	20.000 G=2,5	1,8

APC 14 Slim5

BT50 2–14 mm

A	Part.No.	Form	L1	L2	L3	L4	D1	D2	D3	Balanced	kg
109	300 414Z 450 0	A/AD		38	56	71	24	30	50	20.000 G=2,5	4,0
131	300 414Z 450 1	A/AD		38	61	78	24	30	50	20.000 G=2,5	4,1
167	300 414Z 450 2	A/AD		38	85	103	24	30	50	20.000 G=2,5	4,4

APC 20 Slim5

BT40 2–20 mm

A	Part.No.	Form	L1	L2	L3	L4	D1	D2	D3	Balanced	kg
98	300 420Z 440 0	A/AD		44	54	71	32	39	50	20.000 G=2,5	1,5
120	300 420Z 440 1	A/AD		50	69	78	32	40	50	20.000 G=2,5	1,6
157	300 420Z 440 2	A/AD		50	94	103	32	40	50	20.000 G=2,5	2,0

APC 20 Slim5

BT50 2–20 mm

A	Part.No.	Form	L1	L2	L3	L4	D1	D2	D3	Balanced	kg
109	300 420Z 450 0	A/AD		44	61	71	32	39	63	20.000 G=2,5	4,2
131	300 420Z 450 1	A/AD		50	69	89	32	40	63	20.000 G=2,5	4,4
167	300 420Z 450 2	A/AD		50	94	114	32	40	63	20.000 G=2,5	4,8

APC 25 Slim5

BT40 16–32 mm

A	Part.No.	Form	L1	L2	L3	L4	D1	D2	D3	Balanced	kg
110	300 425Z 440 0	A/AD		66	70		48	58	63	20.000 G=2,5	1,9

APC 25 Slim5

BT50 16–32 mm

A	Part.No.	Form	L1	L2	L3	L4	D1	D2	D3	Balanced	kg
121	300 425Z 450 0	A/AD		66	70	83	48	58	63	20.000 G=2,5	4,5

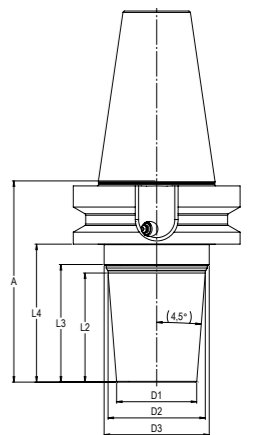

Polygon

Precision Chuck APC, DIN ISO 26623-1 with fine balancing holes 6xM6

Easy exchange of tools by setting of hex-key (see page 59). Maintenance free. Sealed against coolant and contamination. Slow collet taper angle. Collet with special coating (see page 44-57). System-Runout-Accuracy 3 µm at 2,5 x D. Clamping of tool shanks according to DIN 1835 A, B and DIN 6535 HB, HA. Balancing screws see page 96.

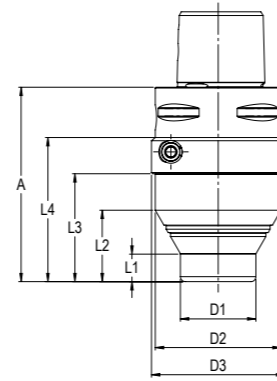

APC 14

PSC 50 2 – 14 mm

A	Part.No.	Form	L1	L2	L3	L4	D1	D2	D3	Balanced	kg
77	300 014Z 9C5 0*	A	11	28	43	57	30	50	53	20.000 G=2,5	0,9
127	300 514Z 9C5 0*	A	61	78	93	107	30	50	53	20.000 G=2,5	1,0

* without balancing holes

PSC 63 2 – 14 mm

A	Part.No.	Form	L1	L2	L3	L4	D1	D2	D3	Balanced	kg
80	300 014Z 9C6 0	A	11	28		43	30	50		20.000 G=2,5	1,3
108	300 614Z 9C6 0	A	39	56		71	30	50		20.000 G=2,5	1,5
130	300 814Z 9C6 0	A	61	78		93	30	50		20.000 G=2,5	1,6
166	300 914Z 9C6 0	A	85	103		129	30	50		20.000 G=2,5	1,9

APC 20

PSC 50 2 – 20 mm

A	Part.No.	Form	L1	L2	L3	L4	D1	D2	D3	Balanced	kg
77	300 120Z 9C5 0*	A	20	31		57	40	53		20.000 G=2,5	0,9

* without balancing holes

PSC 63 2 – 20 mm

A	Part.No.	Form	L1	L2	L3	L4	D1	D2	D3	Balanced	kg
80	300 020Z 9C6 0	A	18	38			40	63		20.000 G=2,5	1,4
108	300 620Z 9C6 0	A	35	55			40	63		20.000 G=2,5	1,9
130	300 820Z 9C6 0	A	47	68			40	63		20.000 G=2,5	2,2
166	300 920Z 9C6 0	A	84	104			40	63		20.000 G=2,5	2,5

APC 20

PSC 80 2 – 20 mm

A	Part.No.	Form	L1	L2	L3	L4	D1	D2	D3	Balanced	kg
90	300 020Z 9C8 0	A	18	38	43		40	63		20.000 G=2,5	3,3
140	300 820Z 9C8 0	A	47	68	93		40	63		20.000 G=2,5	3,5

APC 25

PSC 63 16 – 32 mm

A	Part.No.	Form	L1	L2	L3	L4	D1	D2	D3	Balanced	kg
119	300 025Z 9C6 0	A	14				53	63		20.000 G=2,5	2,4

PSC 80 16 – 32 mm

A	Part.No.	Form	L1	L2	L3	L4	D1	D2	D3	Balanced	kg
129	300 025Z 9C8 0	A	15			83	53	70		20.000 G=2,5	3,8

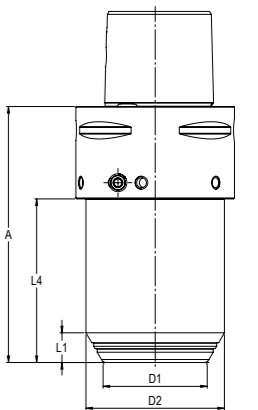

Polygon Slim5

Precision Chuck APC, DIN ISO 26623-1 with fine balancing holes 6xM6

Slim line with 4,5° especially for 5-axis operations. Easy exchange of tools by setting of hex-key (see page 59). Maintenance free. Sealed against coolant and contamination.

Slow collet taper angle. Collet with special coating (see page 44-57).

System-Runout-Accuracy 3 µm at 2,5 x D.

Clamping of tool shanks according to DIN 1835 A, B and DIN 6535 HB, HA.

Balancing screws see page 96.

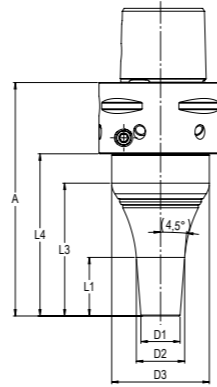

APC 10 Slim5

PSC 63 2-10 mm

A	Part.No.	Form	L1	L2	L3	L4	D1	D2	D3	Balanced	kg
120	300 410Z 9C6 1	A	30		68	83	20	25	50	20.000 G=2,5	1,6
156	300 410Z 9C6 2	A	70		103	119	20	31	50	20.000 G=2,5	1,7

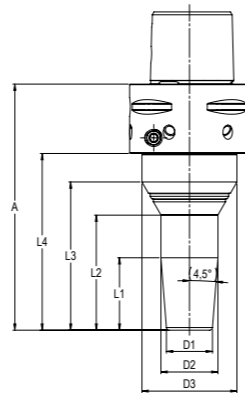

APC 14 Slim5

PSC 63 2-14 mm

A	Part.No.	Form	L1	L2	L3	L4	D1	D2	D3	Balanced	kg
108	300 414Z 9C6 0	A		38	56	71	24	30	50	20.000 G=2,5	1,5
130	300 414Z 9C6 1	A	38	61	78	93	24	30	50	20.000 G=2,5	1,6
166	300 414Z 9C6 2	A	38	58	103	129	24	30	50	20.000 G=2,5	1,9



APC 14 Slim5

PSC 80 2-14 mm

A	Part.No.	Form	L1	L2	L3	L4	D1	D2	D3	Balanced	kg
118	300 414Z 9C8 0	A		38	56	71	24	30	50	20.000 G=2,5	2,7
140	300 414Z 9C8 1	A	38	61	78	93	24	30	50	20.000 G=2,5	2,8
176	300 414Z 9C8 2	A	38	85	103	129	24	30	50	20.000 G=2,5	3,2



APC 20 Slim5

PSC 63 2-20 mm

A	Part.No.	Form	L1	L2	L3	L4	D1	D2	D3	Balanced	kg
108	300 420Z 9C6 0	A		44	54	71	32	39	50	20.000 G=2,5	1,6
130	300 420Z 9C6 1	A	50	69	78	93	32	40	50	20.000 G=2,5	1,7
166	300 420Z 9C6 2	A	50	94	103	129	32	40	50	20.000 G=2,5	2,1



APC 20 Slim5

PSC 80 2-20 mm

A	Part.No.	Form	L1	L2	L3	L4	D1	D2	D3	Balanced	kg
118	300 420Z 9C8 0	A		44	61	71	32	39	63	20.000 G=2,5	2,8
140	300 420Z 9C8 1	A	50	69	89	93	32	40	63	20.000 G=2,5	3,0
176	300 420Z 9C8 2	A	50	94	114	129	32	40	63	20.000 G=2,5	3,5

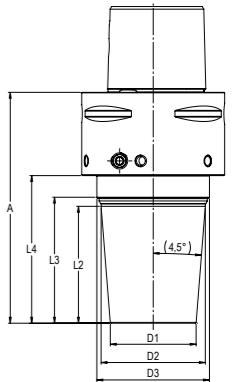

APC 25 Slim5

PSC 63 16-32 mm

A	Part.No.	Form	L1	L2	L3	L4	D1	D2	D3	Balanced	kg
119	300 425Z 9C6 0	A		66	70		48	58	63	20.000 G=2,5	2,0



APC 25 Slim5

PSC 80 16-32 mm

A	Part.No.	Form	L1	L2	L3	L4	D1	D2	D3	Balanced	kg
129	300 425Z 9C8 0	A		66	70	83	48	58	63	20.000 G=2,5	3,2



Dual Contact

Precision Chuck APC, ISO 7388-2 (JIS B 6339) with dual contact

Easy exchange of tools by setting of hex-key (see page 59). Maintenance free.

Sealed against coolant and contamination. Slow collet taper angle.

Collet with special coating (see page 44–57). System-Runout-Accuracy 3 µm at 2,5 x D.

Clamping of tool shanks according to DIN 1835 A, B and DIN 6535 HB, HA.

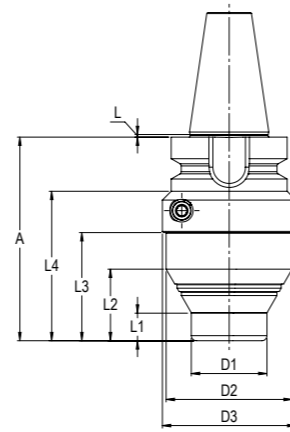

Distance to standard BT-Spindle	L
BT 30*	1,0 -0,005
BT 40*	1,0 -0,005
BT 50*	1,5 -0,005

APC 14

BT30*		2 – 14 mm									
A	Part.No.	Form	L1	L2	L3	L4	D1	D2	D3	Balanced	kg
81	300 014Z 43P 0	A/AD	11	28	43	60	30	50	53	20.000 G=2,5	0,9

BT40*		2 – 14 mm									
A	Part.No.	Form	L1	L2	L3	L4	D1	D2	D3	Balanced	kg
69	300 014Z 44P 0	A/AD	11	28		43	30	50		20.000 G=2,5	1,2
97	300 614Z 44P 0	A/AD	39	56		71	30	50		20.000 G=2,5	1,4
119	300 514Z 44P 0	A/AD	61	78		93	30	50		20.000 G=2,5	1,5
155	300 914Z 44P 0	A/AD	85	103		129	30	50		20.000 G=2,5	2,0

APC 20

BT30*		2 – 20 mm									
A	Part.No.	Form	L1	L2	L3	L4	D1	D2	D3	Balanced	kg
81	300 120Z 43P 0	A/AD	20	31		60	40	53		20.000 G=2,5	0,9

BT40*		2 – 20 mm									
A	Part.No.	Form	L1	L2	L3	L4	D1	D2	D3	Balanced	kg
69	300 020Z 44P 0	A/AD	18	38			40	63		20.000 G=2,5	1,4
98	300 620Z 44P 0	A/AD	35	55			40	63		20.000 G=2,5	1,7
119	300 520Z 44P 0	A/AD	48	68			40	63		20.000 G=2,5	1,8
155	300 920Z 44P 0	A/AD	84	104			40	63		20.000 G=2,5	2,1

APC 20

BT50*		2 – 20 mm									
A	Part.No.	Form	L1	L2	L3	L4	D1	D2	D3	Balanced	kg
80	300 020Z 45P 0	A/AD	18	38		43	40	63		20.000 G=2,5	4,2
130	300 820Z 45P 0	A/AD	48	68		93	40	63		20.000 G=2,5	4,6
166	300 920Z 45P 0	A/AD	84	104		129	40	63		20.000 G=2,5	4,9

APC 25

BT40*		16 – 32 mm									
A	Part.No.	Form	L1	L2	L3	L4	D1	D2	D3	Balanced	kg
109	300 025Z 44P 0	A/AD	14			83	53	63		20.000 G=2,5	2,4

BT50*		16 – 32 mm									
A	Part.No.	Form	L1	L2	L3	L4	D1	D2	D3	Balanced	kg
120	300 025Z 45P 0	A/AD	15			83	53	70		20.000 G=2,5	4,6

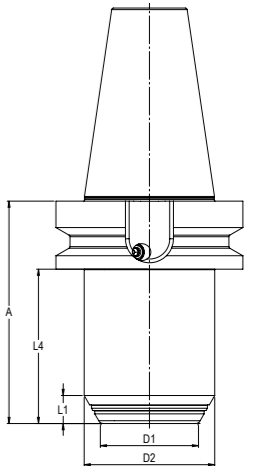

Dual Contact Slim5

Precision Chuck APC, ISO 7388-2 (JIS B 6339) with dual contact

Slim line with 4,5° especially for 5-axis operations. Easy exchange of tools by setting of hex-key (see page 59). Maintenance free. Sealed against coolant and contamination.

Slow collet taper angle. Collet with special coating (see page 44-57).

System-Runout-Accuracy 3 µm at 2,5 x D.

Clamping of tool shanks according to DIN 1835 A, B and DIN 6535 HB, HA.

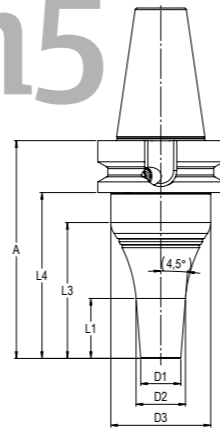

APC 10 Slim5

BT40* 2-10 mm

A	Part.No.	Form	L1	L2	L3	L4	D1	D2	D3	Balanced	kg
109	300 410Z 44P 1	A/AD	30		68	83	20	25	50	20.000 G=2,5	1,5
145	300 410Z 44P 2	A/AD	70		103	119	20	31	50	20.000 G=2,5	1,6

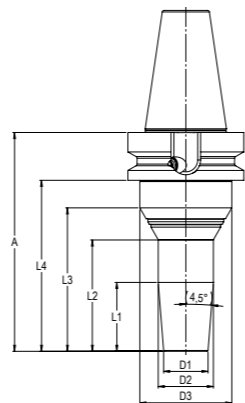

APC 14 Slim5

BT40* 2-14 mm

A	Part.No.	Form	L1	L2	L3	L4	D1	D2	D3	Balanced	kg
97	300 414Z 44P 0	A/AD		38	56	71	24	30	50	20.000 G=2,5	1,4
119	300 414Z 44P 1	A/AD		38	61	78	24	30	50	20.000 G=2,5	1,5
156	300 414Z 44P 2	A/AD		38	85	103	24	30	50	20.000 G=2,5	1,8



APC 14 Slim5

BT50* 2-14 mm

A	Part.No.	Form	L1	L2	L3	L4	D1	D2	D3	Balanced	kg
108	300 414Z 45P 0	A/AD		38	56	71	24	30	50	20.000 G=2,5	4,0
130	300 414Z 45P 1	A/AD		38	61	78	24	30	50	20.000 G=2,5	4,1
166	300 414Z 45P 2	A/AD		38	85	103	24	30	50	20.000 G=2,5	4,4



APC 20 Slim5

BT40* 2-20 mm

A	Part.No.	Form	L1	L2	L3	L4	D1	D2	D3	Balanced	kg
97	300 420Z 44P 0	A/AD		44	54	71	32	39	50	20.000 G=2,5	1,5
119	300 420Z 44P 1	A/AD		50	69	78	32	40	50	20.000 G=2,5	1,6
156	300 420Z 44P 2	A/AD		50	94	103	32	40	50	20.000 G=2,5	2,0



APC 20 Slim5

BT50* 2-20 mm

A	Part.No.	Form	L1	L2	L3	L4	D1	D2	D3	Balanced	kg
108	300 420Z 45P 0	A/AD		44	61	71	32	39	63	20.000 G=2,5	4,2
130	300 420Z 45P 1	A/AD		50	69	89	32	40	63	20.000 G=2,5	4,4
166	300 420Z 45P 2	A/AD		50	94	114	32	40	63	20.000 G=2,5	4,8

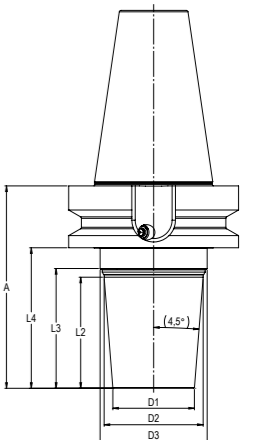

APC 25 Slim5

BT40* 16-32 mm

A	Part.No.	Form	L1	L2	L3	L4	D1	D2	D3	Balanced	kg
109	300 425Z 44P 0	A/AD	14			83	53	63		20.000 G=2,5	2,4



APC 25 Slim5

BT50* 16-32 mm

A	Part.No.	Form	L1	L2	L3	L4	D1	D2	D3	Balanced	kg
120	300 425Z 45P 0	A/AD		66	70	83	48	58	63	20.000 G=2,5	4,5



High-End

Chuck for fine machining

This two-piece design consists of a compensating adapter and a compensating chuck. It permits an adjustment of tools to the μm , especially for long tools and projection lengths. Ideal for high precision reaming and drilling. Axial and radial adjustment is done with different setting screws. Another 6 screws are used for fine balancing. Suitable for inner coolant flow up to a pressure of 80 bar by using a small adapter sleeve between comparison adapter and chuck. The total length (gage-length) is an addition of L1 (adapter) and L4 (chuck). For more information on the handling and μm -precise adjustment see: www.albrecht-germany.com/Instruction



Compensating Chuck APC with fine balancing holes 6xM6

Easy exchange of tools by setting of hex-key (see page 59). Maintenance free. Sealed against coolant and contamination. Slow collet taper angle. Collet with special coating (see page 44-57). Clamping of tool shanks according to DIN 1835 A, B and DIN 6535 HB, HA. Coolant tubes see page 99.

Compensating Adapter

HSK63-Form A

Modul	Part.No.	d	L1	L2	L3	L4	D1	D2	D3	Balanced	kg
70	300 M76Z 663 0	70	60							by design	1,3
80	300 M86Z 663 0	80	60							by design	1,4
100	300 M16Z 663 0	100	65							by design	1,9

HSK100-Form A

Modul	Part.No.	d	L1	L2	L3	L4	D1	D2	D3	Balanced	kg
70	300 M76Z 610 0	70	55							by design	1,6
80	300 M86Z 610 0	80	55							by design	2,8
100	300 M16Z 610 0	100	65							by design	3,7

APC 20

Compensating Chuck

2 – 20 mm

Modul	Part.No.	d	L1	L2	L3	L4	D1	D2	D3	Balanced	kg
70	300 120Z M76 0	70	20	31	72	87	40	53	-	by design	1,1
80	300 120Z M86 0	80	20	31	56	73	40	53	-	by design	1,3

APC 25

16 – 32 mm

Modul	Part.No.	d	L1	L2	L3	L4	D1	D2	D3	Balanced	kg
100	300 025Z M16 0	100	83	-	97	118	63	-	-	by design	3,1

Adapter sleeve for inner coolant flow

Modul	Part.No.	O-Ring
all	139 5004 001 0	17x1,5



APC Individual

The configurable APC from the Albrecht modular system.
Simply select the shank and hood.
Your individual APC is ready.

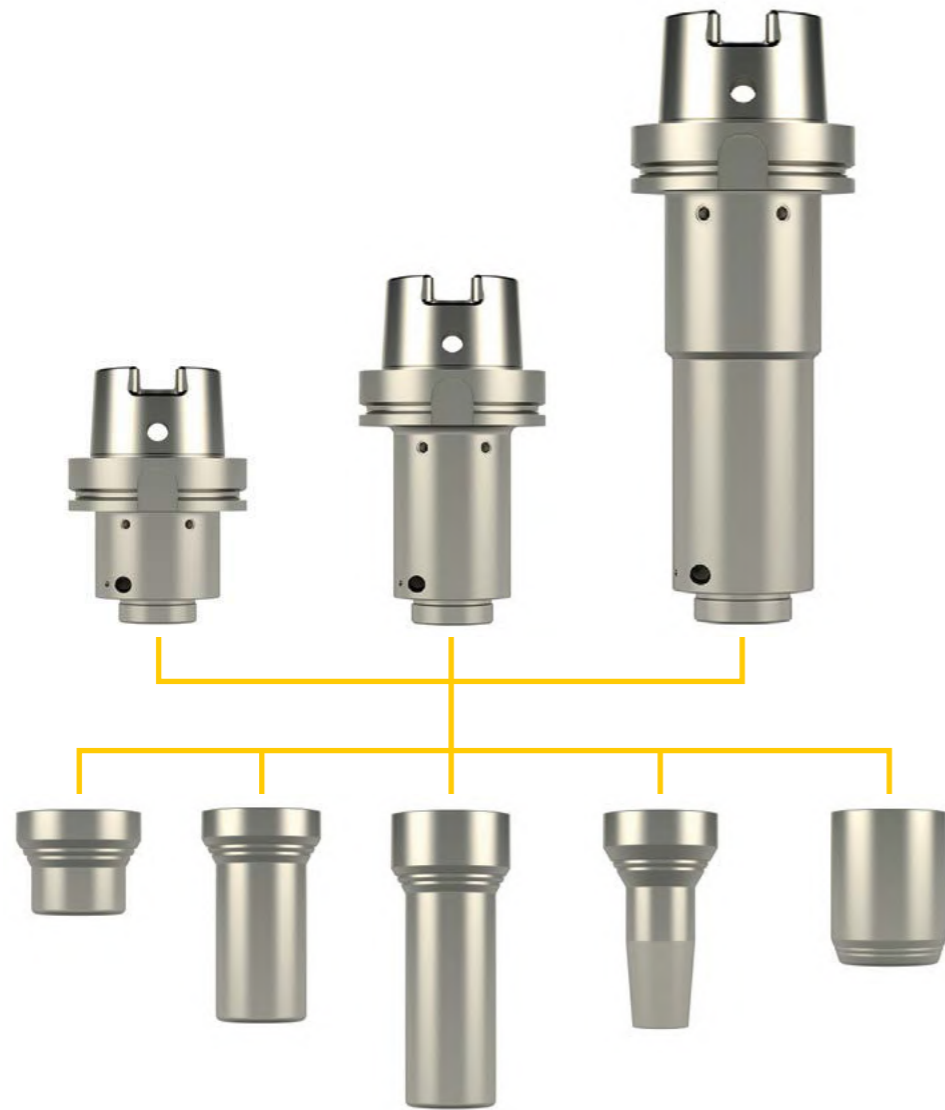

Procedure:

1. Choose shank-side and hood according to your needs, all dimensions can be taken from the tables.
2. Send this to info@albrecht-germany.com with Part.No. of both parts plus the projecting length.
3. We will prepare an offer with a dimensional sketch.

Example:

Shank-side with HSK63 A, Part.No. 135 220Z 663 0 and hood, Part.No. 137 0320 000 2 results in a projecting length of 180 mm.
Details: 135 220Z 663 0, 137 0320 000 2, projecting length 180 mm.

Further HSK-types and details also shown on pages 18-21.

Suitable collets see pages 44-57, accessories see page 59.

APC individually also possible for SK, MAS-BT and Polygon on request.

APC 14/20

APC 14/20, hood cylindrical precision chuck APC, DIN 69893 (DIN ISO 12164)
with fine-balancing holes 6xM6



	Part. No. shank	DA1	DA2	LA1	LA2
HSK63 A	135 220Z 663 0	53	-	87	-
HSK63 A	135 120Z 663 1	53	-	107	-
HSK100 A	135 120Z 610 0	70	-	78	-
HSK100 A	135 320Z 610 0	63	-	121	-
HSK100 A	135 220Z 610 0	63	70	207	100

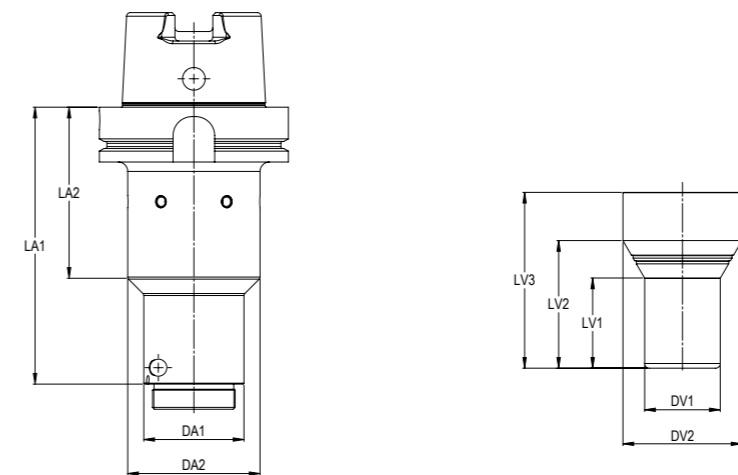

	Part. No. shank	DA1	DA2	LA1	LA2
HSK63 A	135 220Z 663 0	53	-	87	-
HSK63 A	135 120Z 663 1	53	-	107	-
HSK100 A	135 120Z 610 0	70	-	77,5	-
HSK100 A	135 320Z 610 0	63	-	121	-
HSK100 A	135 220Z 610 0	63	70	207	100

2-14 mm

Part. No. hood

	137 0114 000 1	137 0314 000 0	137 0214 000 0
DV1	30	30	30
DV2	50	50	50
LV1	11	61	85
LV2	28	78	103
LV3	43	92,5	129

APC-Variation A

130	180	216
150	200	236
92	142	178
121	170,5	207
164	213	250
250	299	336

2-20 mm

Part. No. hood

	137 0020 000 3	137 0020 000 2	137 0320 000 2	137 0320 000 1	137 0220 000 1	137 0220 000 2
DV1	40	40	40	40	40	40
DV2	53	63	53	63	53	63
LV1	20	18	69	48	94	84
LV2	31	38	81	68	105	104
LV3	43	43	92,5	93	129	129

APC-Variation A

130	-	180	-	216	-
150	-	200	-	236	-
92	-	142	-	178	-
-	120	-	170,5	-	207
-	164	-	214	-	250
-	250	-	300	-	336

APC 25

with fine-balancing holes 6xM6

Procedure:

1. Choose shank-side and hood according Your needs, all dimensions can be taken from the tables.
2. Send this to info@albrecht-germany.com with Part. No. of both parts plus the projecting length.
3. We will prepare an offer with a dimensional sketch.

Example sketch

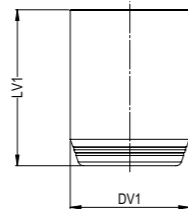
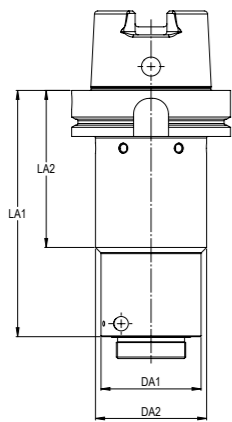
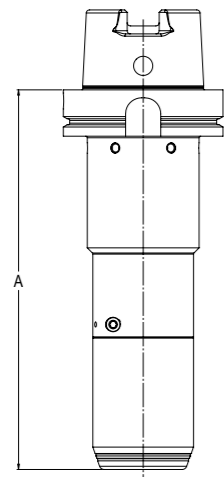

16 – 32 mm

Part.Nr.
hood

	137 0025 000 0	137 0025 000 1
DV1	63	70
LV1	82,5	82,5

APC-Variation
A

160	160
203	-
289	-

	Part. No. shank	DA1	DA2	LA1	LA2
HSK100 A	135 120Z 610 0	70	-	77,5	-
HSK100 A	135 320Z 610 0	63	-	121	-
HSK100 A	135 220Z 610 0	63	70	207	100

Example:

Shank with HSK100-A, Part. No. 135 120Z 610 0 and hood Part. No. 137 0025 000 0 results a projecting length 160 mm. Details 135 120Z 610 0, 137 0025 000 0, projecting length 160 mm.

Further HSK-types and details also shown on pages 18-21.
Suitable collets see pages 54-55, accessories see page 59.

Slim5

APC 14/20, Slim5 precision chuck APC, DIN 69893 (DIN ISO 12164)
with fine-balancing holes 6xM6

2 – 14 mm

Part. No. hood

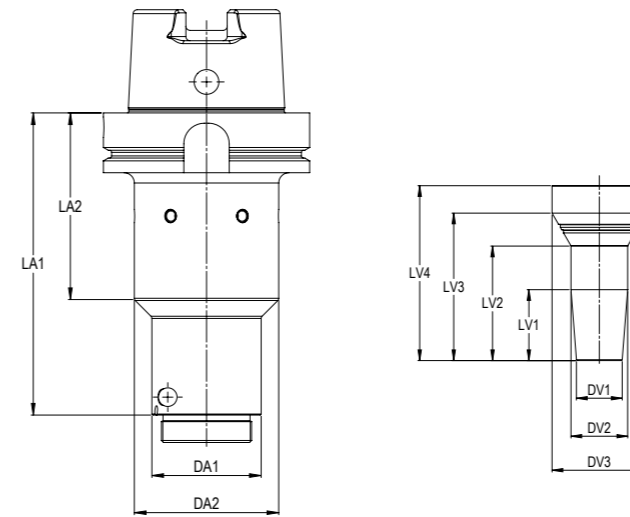

	137 0114 000 2	137 0314 000 1	137 0214 000 1
DV1	24	24	24
DV2	30	30	30
DV3	50	50	50
LV1	-	38	38
LV2	38	61	85
LV3	56	78	103
LV4	71	92,5	129

APC-Variation A

158	180	216
178	200	236
120	142	178
149	170,5	207
192	213	250
278	299	336

	Part. No. shank	DA1	DA2	LA1	LA2
HSK63 A	135 220Z 663 0	53	-	87	-
HSK63 A	135 120Z 663 1	53	-	107	-
HSK100 A	135 120Z 610 0	70	-	78	-
HSK100 A	135 320Z 610 0	63	-	121	-
HSK100 A	135 220Z 610 0	63	70	207	100

2 – 20 mm

Part. No. hood

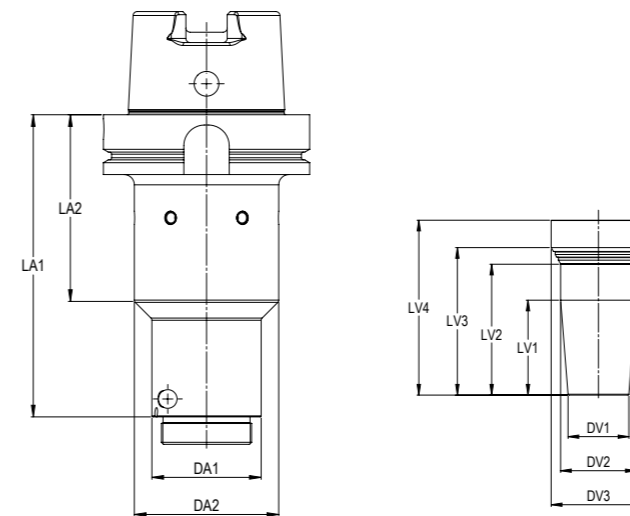

	137 0120 000 2	137 0120 000 5	137 0320 000 3	137 0320 000 5	137 0220 000 3	137 0220 000 5
DV1	32	32	32	32	32	32
DV2	39	39	40	40	40	40
DV3	50	63	50	63	50	63
LV1	-	-	50	50	50	50
LV2	44	44	69	69	94	94
LV3	54	61	78	89	103	114
LV4	71	71	92,5	93	129	129

APC-Variation A

158	-	180	-	216	-
178	-	200	-	236	-
-	149	-	171	-	207
-	192	-	214	-	250
-	278	-	300	-	336

	Part. No. shank	DA1	DA2	LA1	LA2
HSK63 A	135 220Z 663 0	53	-	87	-
HSK63 A	135 120Z 663 1	53	-	107	-
HSK100 A	135 120Z 610 0	70	-	78	-
HSK100 A	135 320Z 610 0	63	-	121	-
HSK100 A	135 220Z 610 0	63	70	207	100

Collets

See page 48–49 **APC 10** Collets 2-10 mm

See page 50–51 **APC 14** Collets 2-14 mm

See page 52–53 **APC 20** Collets 2-20 mm

See page 54–55 **APC 25** Collets 16-32 mm



Coolant Types

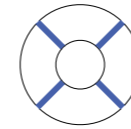

Collets Peripheral Coolant

Additional cooling and rinsing effect. Increases the safety of processing.

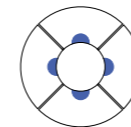

Collets Coolant 2.0

With additional channels for peripheral cooling directly on the tool shank. Up to 60% higher Metal-Removal-Rate (MRR) and tool life.

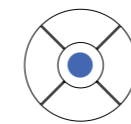

Collets Internal Coolant

For tools with internal coolant.
100% leak proof up to 100 bar coolant pressure.

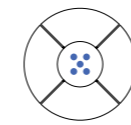

Minimal-Quantity-Lubrication MQL

Set for collets with internal coolant. For 1- and 2-Channel Systems.
See page 56-57



Collets with Pin-Lock

APC collet with mechanical pull stop Pin-Lock

Easy mechanical pull stop solution in combination with side lock (Weldon) shanks corresponding to DIN 6535 HB and DIN 1835 B.

All positive features of APC are kept like runout accuracy and dampening. Special coating. Maintenance free. Collet is supplied with 3 pins, pin punch, assembly tool. Balanced by design in combination with Weldon shank and pin.



Positioning tool

Remove the length setting screw, then position the Weldon-clamping surface on the side of the bore. Now insert the tool into the collet until the Weldon-clamping surface lies in the range of the bore.



Positioning pin

The locking-pin has to be inserted with the help of the pin punch into the bore of the collet up to the block. Caution: The pin must not stick out of the collet.



Free from backlash

With the assembly tool the length stop screw has to be screwed, so that the cutting tool is free of backlash. Caution: Mounting without axial pressure. The collet with the secured tool can now be placed into the APC chuck.

Collets APC10

Special Coating. Maintenance free. Integrated, fine adjustable length stop.
Clamping of tool shanks corresponding to DIN 1835 A, B and DIN 6535 HB, HA.

Peripheral Coolant



included length stop

Coolant 2.0



included length stop

Central Coolant



included length stop

D	Part.No.	Balanced	Part.No.	Balanced
2,0	136 1002 000 0	yes		
3,0	136 1003 000 0	yes		
4,0	136 1004 000 0	yes		
5,0	136 1005 000 0	yes		
6,0	136 1006 000 0	yes	136 1006 000 P	yes
7,0	136 1007 000 0	yes		
8,0	136 1008 000 0	yes	136 1008 000 P	yes
9,0	136 1009 000 0	yes		
10,0	136 1010 000 0	yes	136 1010 000 P	yes

special sizes and inch diameter on request

D	Part.No.	Balanced
2,0	136 1402 000 T	yes
3,0	136 1403 000 T	yes
4,0	136 1404 000 T	yes
5,0	136 1405 000 T	yes
6,0	136 1406 000 T	yes
7,0	136 1407 000 T	yes
8,0	136 1408 000 T	yes
9,0	136 1409 000 T	yes
10,0	136 1410 000 T	yes

special sizes and inch diameter on request

Collets APC14

Special Coating. Maintenance free. Integrated, fine adjustable length stop.
Clamping of tool shanks corresponding to DIN 1835 A, B and DIN 6535 HB, HA.

Peripheral Coolant



included length stop

Coolant 2.0



included length stop

**Coolant 2.0
Pin-Lock for Weldon shanks**



included length stop
with 3 pins and assembly tool

Central Coolant



included length stop

**Central Coolant
Pin-Lock for Weldon shanks**



included length stop
with 3 pins and assembly tool

D	Part.No.	Balanced	Part.No.	Balanced	Part.No.	Balanced
2,0	136 1402 000 0	yes				
3,0	136 1403 000 0	yes				
4,0	136 1404 000 0	yes				
5,0	136 1405 000 0	yes				
6,0	136 1406 000 0	yes	136 1406 000 P	yes		
7,0	136 1407 000 0	yes				
8,0	136 1408 000 0	yes	136 1408 000 P	yes		
9,0	136 1409 000 0	yes				
10,0	136 1410 000 0	yes	136 1410 000 P	yes	136 1410 0LO P	no
11,0	136 1411 000 0	yes				
12,0	136 1412 000 0	yes	136 1412 000 P	yes	136 1412 0LO P	no
14,0	136 1414 000 0	yes				

special sizes and inch diameter on request

D	Part.No.	Balanced	Part.No.	Balanced
2,0	136 1402 000 T	yes		
3,0	136 1403 000 T	yes		
4,0	136 1404 000 T	yes		
5,0	136 1405 000 T	yes		
6,0	136 1406 000 T	yes		
7,0	136 1407 000 T	yes		
8,0	136 1408 000 T	yes		
9,0	136 1409 000 T	yes		
10,0	136 1410 000 T	yes	136 1410 0LO T	no
11,0	136 1411 000 T	yes		
12,0	136 1412 000 T	yes	136 1412 0LO T	no
14,0	136 1414 000 T	yes		

special sizes and inch diameter on request

Collets APC20

Special Coating. Maintenance free. Integrated, fine adjustable length stop.
Clamping of tool shanks corresponding to DIN 1835 A, B and DIN 6535 HB, HA.

Peripheral Coolant



included length stop

Coolant 2.0



included length stop

**Coolant 2.0
Pin-Lock for Weldon shanks**



included length stop
with 3 pins and assembly tool
Balanced by design for operation
with Weldon-Shank, made out of
hard-metal and included Pin

Central Coolant



included length stop

**Central Coolant
Pin-Lock for Weldon shanks**



included length stop
with 3 pins and assembly tool
Balanced by design for operation
with Weldon-Shank, made out of
hard-metal and included Pin

D	Part.No.	Balanced	Part.No.	Balanced	Part.No.	Balanced
2,0	136 2002 000 0	yes				
3,0	136 2003 000 0	yes				
4,0	136 2004 000 0	yes				
5,0	136 2005 000 0	yes				
6,0	136 2006 000 0	yes	136 2006 000 P	yes	136 2006 0LO P	yes
7,0	136 2007 000 0	yes				
8,0	136 2008 000 0	yes	136 2008 000 P	yes	136 2008 0LO P	yes
9,0	136 2009 000 0	yes				
10,0	136 2010 000 0	yes	136 2010 000 P	yes	136 2010 0LO P	yes
11,0	136 2011 000 0	yes				
12,0	136 2012 000 0	yes	136 2012 000 P	yes	136 2012 0LO P	yes
13,0	136 2013 000 0	yes				
14,0	136 2014 000 0	yes	136 2014 000 P	yes	136 2014 0LO P	yes
15,0	136 2015 000 0	yes				
16,0	136 2016 000 0	yes	136 2016 000 P	yes	136 2016 0LO P	yes
17,0	136 2017 000 0	yes				
18,0	136 2018 000 0*	yes	see Peripheral Collets		136 2018 0LO 0 *	no
20,0	136 2020 000 0*	yes	see Peripheral Collets		136 2020 0LO 0 *	no

special sizes and inch diameter on request

* with extended slots

D	Part.No.	Balanced	Part.No.	Balanced
2,0	136 2002 000 T	yes		
3,0	136 2003 000 T	yes		
4,0	136 2004 000 T	yes		
5,0	136 2005 000 T	yes		
6,0	136 2006 000 T	yes		
7,0	136 2007 000 T	yes		
8,0	136 2008 000 T	yes		
9,0	136 2009 000 T	yes		
10,0	136 2010 000 T	yes	136 2010 0LO T	yes
11,0	136 2011 000 T	yes		
12,0	136 2012 000 T	yes	136 2012 0LO T	yes
13,0	136 2013 000 T	yes		
14,0	136 2014 000 T	yes	136 2014 0LO T	yes
15,0	136 2015 000 T	yes		
16,0	136 2016 000 T	yes	136 2016 0LO T	yes
17,0	136 2017 000 T	yes		
18,0	136 2018 000 T	yes	136 2018 0LO T	no
20,0	136 2020 000 T	yes	136 2020 0LO T	no

special sizes and inch diameter on request

Collets APC25

Special Coating. Maintenance free. Integrated, fine adjustable length stop.
Clamping of tool shanks corresponding to DIN 1835 A, B and DIN 6535 HB, HA.

Peripheral Coolant



included length stop

**Coolant 2.0
Pin-Lock for Weldon shanks**



included length stop
with 3 pins and assembly tool
Balanced by design for operation
with Weldon-Shank, made out of
hard-metal and included Pin

Central Coolant



included length stop

**Central Coolant
Pin-Lock for Weldon shanks**



included length stop
with 3 pins and assembly tool
Balanced by design for operation
with Weldon-Shank, made out of
hard-metal and included Pin

D	Part.No.	Balanced	Part.No.	Balanced
16,0	136 2516 000 0	yes	136 2516 OLO P	yes
18,0	136 2518 000 0	yes	136 2518 OLO P	yes
20,0	136 2520 000 0	yes	136 2520 OLO P	yes
22,0	136 2522 000 0	yes	136 2522 OLO P	no
25,0	136 2525 000 0	yes	136 2525 OLO P	no
32,0	136 2532 000 0	yes	136 2532 OLO O*	no

special sizes and inch diameter on request

*with extended slots instead of
additional channels

D	Part.No.	Balanced	Part.No.	Balanced
16,0	136 2516 000 T	yes	136 2516 OLO T	yes
18,0	136 2518 000 T	yes	136 2518 OLO T	yes
20,0	136 2520 000 T	yes	136 2520 OLO T	yes
22,0	136 2522 000 T	yes	136 2522 OLO T	no
25,0	136 2525 000 T	yes	136 2525 OLO T	no
32,0	136 2532 000 T	yes	136 2532 OLO T	no

special sizes and inch diameter on request

MQL inside

MQL by Albrecht

Of course the APC Precision Chuck is also available with Minimum-Quantity-Lubrication. For 1- and 2-Channel-systems in combination with central coolant collets. Please choose your MQL Length screw and Coolant tube alternatively 1- or 2-channel. 100% perfect matched set with MQL conform delivery at the tool shaft end with 90°. Based on MQL company standard. Insertion depth corresponding to DIN 1835 and DIN 6535.



Albrecht MQL, minimum quantity lubrication

In combination with Central Coolant Collets, see page 51 and 53.

DIN 69893 HSK 50 Form A (300 014Z 650 0 and 300 120Z 650 0)

ø	MQL Length screw Part.No.	Coolant tube 1-channel Part.No.	Coolant tube 2-channel Part.No.
4 - 6	132 0004 000 3	139 0008 650 2	139 0004 650 2
8	132 0008 000 3	139 0008 650 2	139 0004 650 2
10	132 0010 000 3	139 0008 650 2	139 0004 650 2
12	132 0012 000 3	139 0008 650 2	139 0004 650 2
14	132 0014 000 3	139 0008 650 2	139 0004 650 2
16	132 0016 000 3	139 0008 650 2	139 0004 650 2
18	132 0018 000 3	139 0008 650 2	139 0004 650 2
20	132 0020 000 3	139 0008 650 2	139 0004 650 2

DIN 69893 HSK 63 Form A (300 014Z 663 0 and 300 120Z 663 0)

ø	MQL Length screw Part.No.	Coolant tube 1-channel Part.No.	Coolant tube 2-channel Part.No.
4 - 6	132 0004 000 3	139 0008 663 2	139 0004 663 2
8	132 0008 000 3	139 0008 663 2	139 0004 663 2
10	132 0010 000 3	139 0008 663 2	139 0004 663 2
12	132 0012 000 3	139 0008 663 2	139 0004 663 2
14	132 0014 000 3	139 0008 663 2	139 0004 663 2
16	132 0016 000 3	139 0008 663 2	139 0004 663 2
18	132 0018 000 3	139 0008 663 2	139 0004 663 2
20	132 0020 000 3	139 0008 663 2	139 0004 663 2

DIN 69893 HSK 80 Form A (300 020Z 680 0)

ø	MQL Length screw Part.No.	Coolant tube 1-channel Part.No.	Coolant tube 2-channel Part.No.
4 - 6	132 0004 000 3	139 0008 680 2	139 0004 680 0
8	132 0008 000 3	139 0008 680 2	139 0004 680 0
10	132 0010 000 3	139 0008 680 2	139 0004 680 0
12	132 0012 000 3	139 0008 680 2	139 0004 680 0
14	132 0014 000 3	139 0008 680 2	139 0004 680 0
16	132 0016 000 3	139 0008 680 2	139 0004 680 0
18	132 0018 000 3	139 0008 680 2	139 0004 680 0
20	132 0020 000 3	139 0008 680 2	139 0004 680 0

DIN 69893 HSK 100 Form A (300 020Z 610 0)

ø	MQL Length screw Part.No.	Coolant tube 1-channel Part.No.	Coolant tube 2-channel Part.No.
4 - 6	132 0004 000 3	139 0008 610 2	139 0004 610 0
8	132 0008 000 3	139 0008 610 2	139 0004 610 0
10	132 0010 000 3	139 0008 610 2	139 0004 610 0
12	132 0012 000 3	139 0008 610 2	139 0004 610 0
14	132 0014 000 3	139 0008 610 2	139 0004 610 0
16	132 0016 000 3	139 0008 610 2	139 0004 610 0
18	132 0018 000 3	139 0008 610 2	139 0004 610 0
20	132 0020 000 3	139 0008 610 2	139 0004 610 0

extended coolant tubes for APC-Chucks with longer gage-length on request

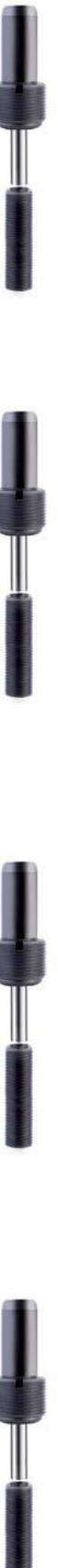

Accessories



Standard Key	Part.No.
with marking approx.10 Nm	139 0000 905 0

Torque Key	Part.No.
corr. ISO 6789 at 10 Nm	139 0010 900 0
Spare bit 1/4"	139 0000 901 4

for Screwdriver	Part.No.
torque limiter at 10 Nm The Chuck must be fixed in a device, see page 98-99	139 0010 901 0
spare bit 3/8"	139 0010 901 4

Akkuschrauber Bosch Exact Ion	Part.No.
The Screwdriver is ideal for quick and safer clamping of all APC Chucks. Fixed speed levels and automatic shutdown when the target torque of 10 Nm is reached. Meets the requirements of a torque wrench. Supplied with a matching bit. The associated Bosch battery is not included in the scope of delivery and must be ordered separately. The Chuck must be fixed in a device, see page 98-99	730 0010 901 0

*Battery pack 18V, 2,0Ah, Li-Ion for Bosch Exact Ion (Bosch-Order-No.: 0 602 494 002/1)	730 0010 920 0
--	----------------

*Charger for Bosch Exact Ion (Bosch-Order-No.: 0 602 494 035/1)	730 0010 910 0
--	----------------

spare bit	139 0012 901 3
-----------	----------------

*for deliveries outside of Germany, buy the battery and charger in the country of use

Taper Wiper	Part.No.
für APC 10	139 0000 GR3 0
Replacement papers, 25 pcs.	139 0000 GRO 2*
für APC 14	139 0000 GR1 0
für APC 20	139 0000 GR2 0
für APC 25	139 0000 GR4 0

for Part.No. 139 0000 GR3 0

Spare-Pins for Pin-Lock		
DxL	for	Part.No.
Ø3x10 (3 pieces)	APC14 Ø8-10	139 3020 310 0
Ø2x10 (3 pieces)	APC14 Ø12	139 3020 210 0
Ø2x12 (3 pieces)	APC20 Ø18	139 3020 212 0
Ø3x8 (3 pieces)	APC20 Ø20	139 3020 308 0
Ø3x12 (3 pieces)	APC20 Ø16	139 3020 312 0
Ø3x14 (3 pieces)	APC20 Ø6-14	139 3020 314 0
Ø4x12 (3 pieces)	APC25 Ø32	139 3025 412 0
Ø4x20 (3 pieces)	APC25 Ø22-25	139 3025 420 0
Ø4x26 (3 pieces)	APC25 Ø16-20	139 3025 426 0

Storage	Dimensions	Part.No.
for 24 Collets, APC 10 and APC 14	345x250x30	V01 FP14 024 0
for 21 Collets, APC 20	345x250x30	V01 FP20 021 0
for 10 Collets, APC 25	345x250x50	V01 FP25 010 0



Clamping Device

With the Albrecht clamping device you can clamp the APC precision chucks quickly and precisely. The torque generated at the screwdriver is completely absorbed by the clamping station. In this way, many clamping processes can be carried out quickly and with little effort. To prevent the clamping device from slipping, we recommend to secure it by the 4 existing holes, designed for M10 screws.

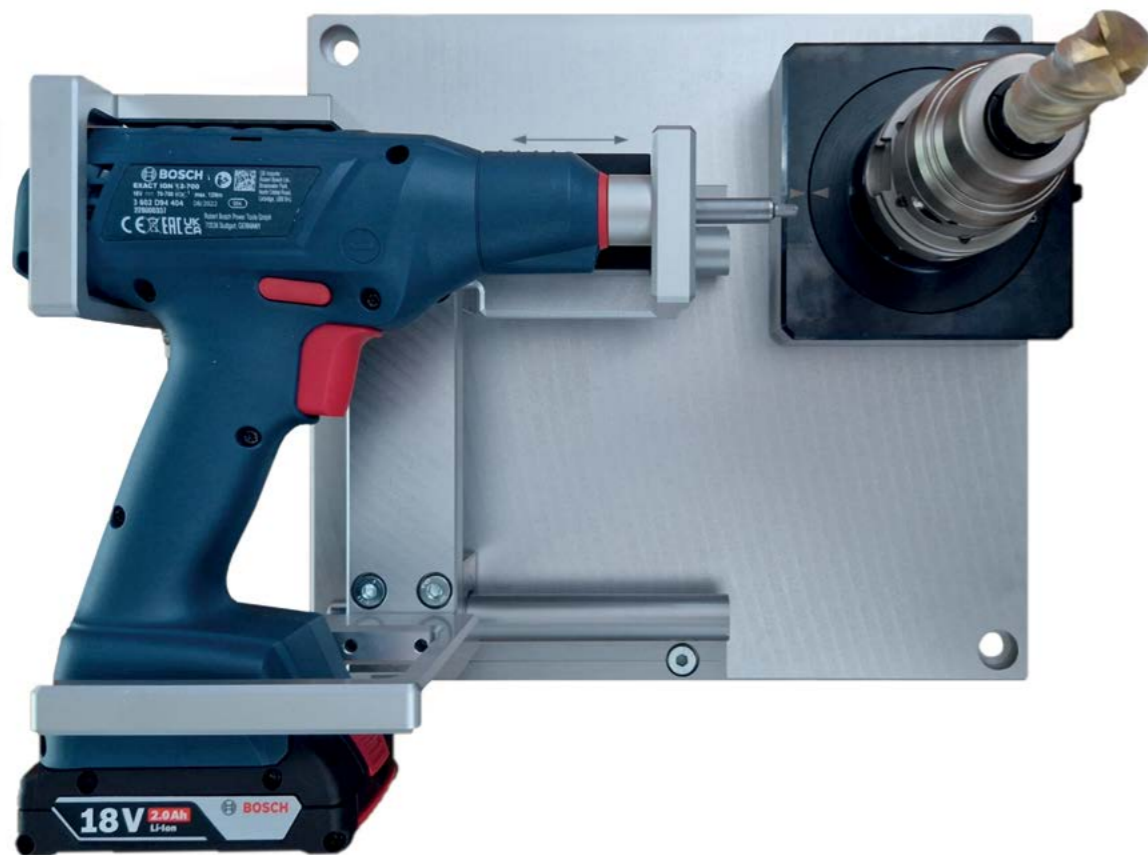

APC Clamping Device	Part.No.
for all APC types, delivery without Bosch cordless screwdriver and changeable adapter	730 0020 000 0



Akkuschrauber Bosch Exact Ion	Part.No.
The Screwdriver is ideal for quick and safer clamping of all APC Chucks. Fixed speed levels and automatic shutdown when the target torque of 10 Nm is reached. Meets the requirements of a torque wrench. Supplied with a matching bit. The associated Bosch battery is not included in the scope of delivery and must be ordered separately.	730 0010 901 0
*Battery pack 18V, 2,0Ah, Li-Ion for Bosch Exact Ion (Bosch-Order-No.: 0 602 494 002/1)	730 0010 920 0
*Charger for Bosch Exact Ion (Bosch-Order-No.: 0 602 494 035/1)	730 0010 910 0
spare bit	139 0012 901 3



Adapters	Part.No.
ISO 7388-1*	
SK40 + CAT40	730 0020 240 0
SK50 + CAT50	730 0020 250 0
ISO 7388-2*	
BT30	730 0020 430 0
BT40	730 0020 440 0
BT50	730 0020 450 0
DIN 69893	
HSK-A-63	730 0020 663 0
HSK-A-100	730 0020 610 0
ISO 26623-1	
PSC63	730 0020 9C6 0



* Adapter for Chucks with dual contact on request

Ultra Maximize your work

**Highest metal
removal rate.
Adaptive cooling.
Safety of processing
with Pin-Lock.**

ALBRECHT
Germany

Ultra metal removal rate.
Ultra-Gripping.
Ultra-Dampening.
Ultra-Safe due to Pin-Lock.
In addition peripheral cooling
which adapts perfectly to
every task.

Up to 33.000 rpm.
Runout $\leq 3 \mu\text{m}$.
Cooling-Ring 10-30°.

Albrecht Ultra – The basis
for record-setting.



Ultra Power Chuck



Ideal in combination
with collets Coolant 2.0
For a coolant supply
directly to the tool shaft

Recommended collets,
see page 69
- Coolant 2.0
- Coolant 2.0 Pin-Lock
- Central Coolant Pin-Lock

HSK

Precision Chuck Ultra Power, DIN 69893 (ISO 12164) with fine balancing holes 6xM6

Easy exchange of tools by using a hex-key (see page 69). Maintenance-free.
Sealed against coolant and contamination. Slow collet taper angle.
Collet with special coating (see page 69). System-Runout-Accuracy 3 µm at 2,5 x D.
Clamping of tool shanks according to DIN 1835 A, B and DIN 6535 HB, HA.
Balancing screws see page 96. Coolant tubes see page 99.

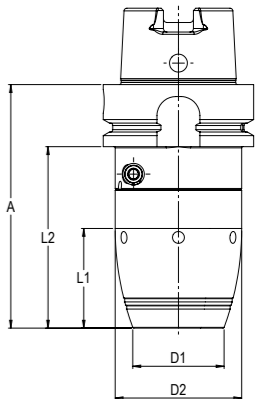

Application examples: Ultra in operation

Material	Tensile strength [N/mm ²]	Milling-Ø [mm]	Speed [r.p.m.]	vf [mm/min]	ae [mm]	ap [mm]	MRR [cm ³ /min]
Titanium Ti 6-4		20	2.800	896	20	25	448
1.2892	1500	20	2.389	1.194	1	40	48
Aluminium 7075		25	30.000	13.500	25	40	13.500
Toolox 33	1080	20	2.800	1.758	2,5	35	154

Ultra Power Chuck 20

HSK63 A		16 – 20 mm						
A	Part.No.	Form	L1	L2	D1	D2	Balanced	kg
102	360 020Z 663 0	A	42	76	38	53	20.000 G=2,5	1,6
HSK80 A								
108	360 020Z 680 0	A	42	82	38	53	20.000 G=2,5	2,2
HSK100 A								
110	360 020Z 610 0	A	42	81	38	53	20.000 G=2,5	3,0



Ultra Power Chuck 25

HSK63 A		16 – 25 mm						
A	Part.No.	Form	L1	L2	D1	D2	Balanced	kg
110	360 025Z 663 0	A	47	84	44	53	20.000 G=2,5	1,7
HSK80 A								
116	360 025Z 680 0	A	47	90	44	53	20.000 G=2,5	2,2
HSK100 A								
118	360 025Z 610 0	A	47	89	44	53	20.000 G=2,5	3,2



Ultra Adaptive Cooling



Delivery state: For cutting tools with internal coolant supply
Recommended collets, see page 69
- Central Coolant Pin-Lock

Exchangeable Cooling-Rings:

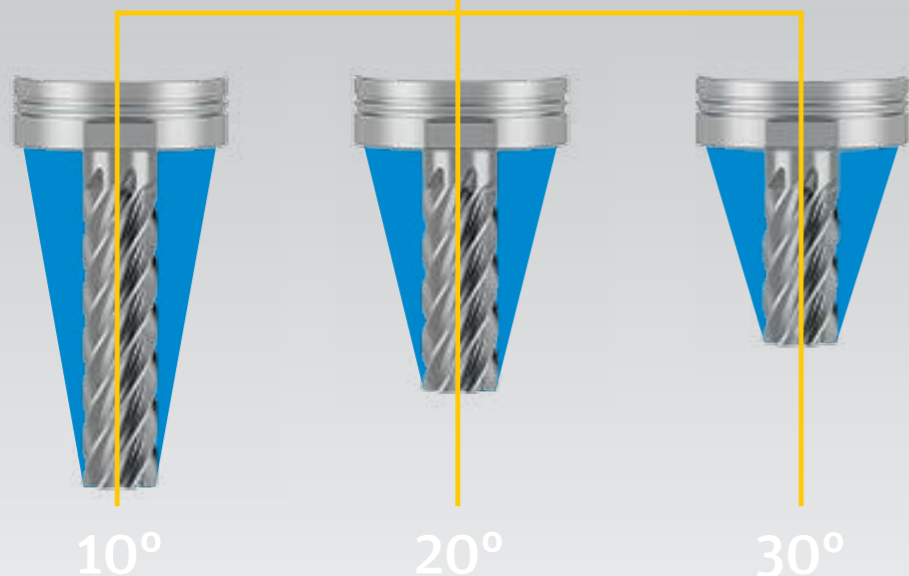

HSK

Precision Chuck Ultra with adaptive cooling, DIN 69893 (ISO 12164) with fine balancing holes 6xM6

Easy exchange of tools by using a hex-key (see page 69). Maintenance-free.
Sealed against coolant and contamination. Slow collet taper angle.
Collet with special coating (see page 69). System-Runout-Accuracy 3 µm at 2,5 x D.
Clamping of tool shanks according to DIN 1835 A, B and DIN 6535 HB, HA.
Delivery state for cutting tools with internal coolant supply.
Changeable cooling ring for peripheral coolant.
Balancing screws see page 96. Coolant tubes see page 99.

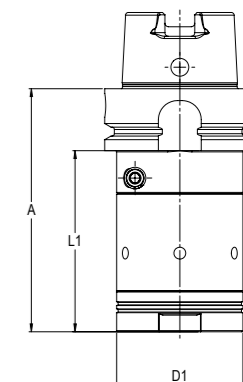

Ultra Power Chuck 20

HSK63 A						16 – 20 mm
A	Part.No.	Form	L1	D1	Balanced	kg
102	360 020A 663 0	A	76	53	20.000 G=2,5	1,5
HSK80 A						
108	360 020A 680 0	A	82	53	20.000 G=2,5	2,0
HSK100 A						
110	360 020A 610 0	A	81	53	20.000 G=2,5	2,9



Ultra Power Chuck 25

HSK63 A						16 – 25 mm
A	Part.No.	Form	L1	D1	Balanced	kg
110	360 025A 663 0	A	84	53	20.000 G=2,5	1,4
HSK80 A						
116	360 025A 680 0	A	90	53	20.000 G=2,5	2,0
HSK100 A						
118	360 025A 610 0	A	89	53	20.000 G=2,5	2,9



Cooling-Ring

no. of holes and angle	AF	Part.No.
4 x 10°	50	161 2025 000 1
6 x 20°	50	161 2025 000 2
6 x 30°	50	161 2025 000 3
Set consisting of 4 x 10° / 6 x 20° / 6 x 30°		161 2025 S00 0



Collets with Pin-Lock

Ultra collet with mechanical pull stop Pin-Lock

Easy mechanical pull stop solution in combination with side lock (Weldon) shanks corresponding to DIN 6535 HB and DIN 1835 B.

All positive features of Ultra are kept like runout accuracy and dampening. Special coating. Maintenance free. Collet is supplied with 3 pins, pin punch, assembly tool. Balanced by design in combination with Weldon shank and pin.

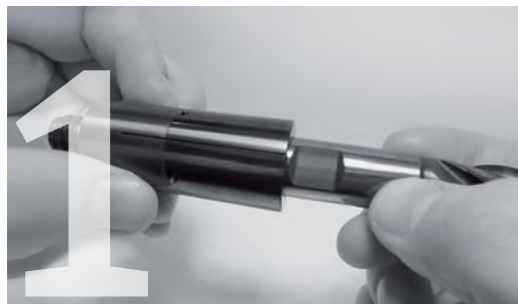

Positioning tool

Remove the length setting screw, then position the Weldon-clamping surface on the side of the bore. Now insert the tool into the collet until the Weldon-clamping surface lies in the range of the bore.



Positioning pin

The locking-pin has to be inserted with the help of the pin punch into the bore of the collet up to the block. Caution: The pin must not stick out of the collet.



Free from backlash

With the assembly tool the length stop screw has to be screwed, so that the cutting tool is free of backlash. Caution: Mounting without axial pressure. The collet with the secured tool can now be placed into the Ultra-chuck.

Special Coating. Maintenance free. Integrated, fine adjustable length stop.

Clamping of tool shanks corresponding to DIN 1835 A, B and DIN 6535 HB, HA.



Ultra 20

D	Part.No.	Part.No.	Part.No.
16,0	166 2016 000 P	166 2016 OLO P	166 2016 OLO T
20,0	166 2020 000 P	166 2020 OLO P	166 2020 OLO T

Ultra 25

D	Part.No.	Part.No.	Part.No.
16,0	166 2516 000 P	166 2516 OLO P	166 2516 OLO T
20,0	166 2520 000 P	166 2520 OLO P	166 2520 OLO T
25,0	166 2525 000 P	166 2525 OLO P	166 2525 OLO T

Standard Key

With marking approx. 12 Nm

Part.No.

139 0000 906 0

Torque Key

corresponding ISO 6789 at 12 Nm

Part.No.

139 0012 900 0

Spare bit ¼"

139 0000 901 4

Spare part

Spare Pins for Pin-Lock

DxL	for	Part.No.
Ø3x14 (3 pieces)	Ultra20 Ø16 and Ø20	139 3020 314 0
Ø4x20 (3 pieces)	Ultra25 Ø20	139 3025 420 0
Ø4x16 (3 pieces)	Ultra25 Ø25	139 3025 416 0



Micro Reach the peak

**Made for the
smallest and finest
surfaces. Range
1 - 6 Millimeter.**

ALBRECHT
GERMANY

Ideal for microtools.
Clamping range 1 - 6 mm.
Peripheral or internal cooling.
Significantly better dampening
in comparison to Shrink Chucks.
Slim shape D1=13,5 mm.
Perfect runout $\leq 3 \mu\text{m}$ 2,5xD.
Up to 40.000 1/min $\leq 1 \text{ gmm}$.

For the finest surfaces even for
difficulty accessible areas.
Special coated collets.
Maintenance-free.
The Albrecht Micro.
None is more fine.



Micro Chuck-Extension

For extension of Precision Chucks.
Very slim design for operation areas which are not easy to access. High gripping torque and accuracy due to slow angle taper.



Micro Precision-Chuck-Extension with Cylindrical Shank.

Easy exchange of tools by setting of hex-key (included in delivery). Maintenance free. Sealed against coolant and contamination. Slow collet taper angle. Collet with special coating (see page 79). Clamping of tool shanks according to DIN 1835 A, B and DIN 6535 HB, HA. Tolerance of shank h6. System-Runout-Accuracy 8 µm at 2,5 x D.

Cylindrical shank 14 mm

1 – 6 mm

L1	Part.No.	Coolant	L2	D1	D2	AF	kg
100	310 1006 814 1	Central	29	13	14	13	0,16
150	310 2006 814 1	Central	29	13	14	13	0,10

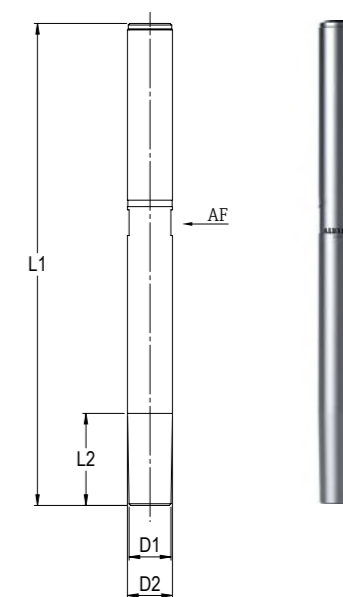

Cylindrical shank 20 mm

1 – 6 mm

L1	Part.No.	Coolant	L2	D1	D2	AF	kg
100	310 1006 820 1	Central	45	13	20	13	0,17
150	310 2006 820 1	Central	67	13	20	19	0,30

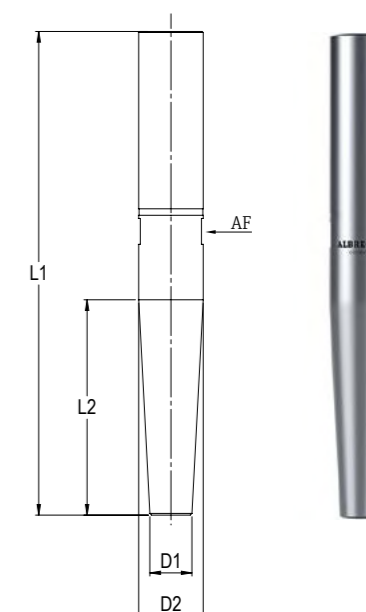

HSK

Micro Precision Chuck, ISO 12164 (DIN 69893)

Easy exchange of tools by setting of hex-key (included in delivery). Maintenance free. Sealed against coolant and contamination. Slow collet taper angle. Collet with special coating (see page 79). System-Runout-Accuracy 3 µm at 2,5 x D. Clamping of tool shanks according to DIN 1835 A, B and DIN 6535 HB, HA. Coolant tubes see page 99.

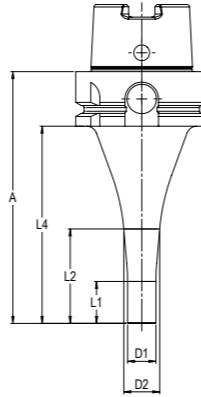

HSK 40-A		1 – 6 mm								
A	Part.No.	Form	L1	L2	L4	D1	D2	Balanced	kg	
75	310 1006 640 1	A	20	35	55	13,5	16	<1gmm	0,3	
HSK 40-E										
75	310 10E6 640 1	E	20	35	55	13,5	16	<1gmm	0,3	
HSK 50-A										
85	310 1006 650 1	A	20	34	59	13,5	16	<1gmm	0,5	
120	310 2006 650 1	A	20	45	94	13,5	18	<1gmm	0,7	
HSK 50-E										
85	310 10E6 650 1	E	20	40	59	13,5	17	<1gmm	0,5	
120	310 20E6 650 1	E	20	45	94	13,5	18	<1gmm	0,7	
HSK 63-A										
90	310 1006 663 1	A	20	30	64	13,5	15	20.000 G=2,5	0,8	
120	310 2006 663 1	A	20	45	94	13,5	17	20.000 G=2,5	1,0	
160	310 3006 663 1	A	20	70	134	13,5	22	20.000 G=2,5	1,2	
HSK 63-F										
90	310 10F6 663 1	F	20	30	64	13,5	15	20.000 G=2,5	0,8	
120	310 20F6 663 1	F	20	45	94	13,5	17	20.000 G=2,5	1,0	

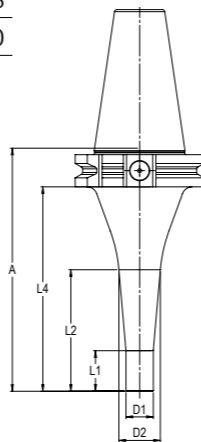

SK

Micro Precision Chuck, ISO 7388-1 (DIN 69871)

Easy exchange of tools by setting of hex-key (included in delivery). Maintenance free. Sealed against coolant and contamination. Slow collet taper angle. Collet with special coating (see page 79). System-Runout-Accuracy 3 µm at 2,5 x D. Clamping of tool shanks according to DIN 1835 A, B and DIN 6535 HB, HA.

SK 30		1 – 6 mm								
A	Part.No.	Form	L1	L2	L4	D1	D2	Balanced	kg	
75	310 2006 230 1	A/AD	20	32	56	13,5	16	<1gmm	0,5	
SK 40										
90	310 1006 240 1	A/AD	20	38	71	13,5	17	20.000 G=2,5	1,0	
120	310 2006 240 1	A/AD	20	60	101	13,5	21	20.000 G=2,5	1,2	
160	310 3006 240 1	A/AD	20	75	141	13,5	23	20.000 G=2,5	1,2	



MAS-BT

Micro Precision Chuck, ISO 7388-2 (JIS B 6339)

Easy exchange of tools by setting of hex-key (included in delivery). Maintenance free. Sealed against coolant and contamination. Slow collet taper angle. Collet with special coating (see page 79). System-Runout-Accuracy 3 µm at 2,5 x D. Clamping of tool shanks according to DIN 1835 A, B and DIN 6535 HB, HA.

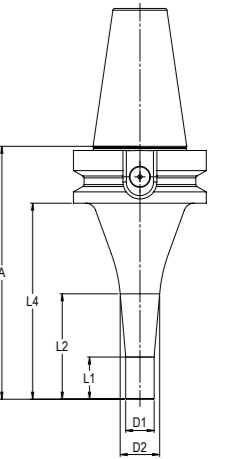

BT 30		1 – 6 mm								
A	Part.No.	Form	L1	L2	L4	D1	D2	Balanced	kg	
75	310 2006 430 1	A/AD	20	30	53	13,5	15	<1gmm	0,5	
BT 40										
90	310 1006 440 1	A/AD	20	30	63	13,5	15	20.000 G=2,5	1,2	
120	310 2006 440 1	A/AD	20	50	93	13,5	19	20.000 G=2,5	1,3	
160	310 3006 440 1	A/AD	20	70	133	13,5	22	20.000 G=2,5	1,3	



Polygon

Micro Precision Chuck, DIN ISO 26623-1

Easy exchange of tools by setting of hex-key (included in delivery). Maintenance free. Sealed against coolant and contamination. Slow collet taper angle. Collet with special coating (see page 79). System-Runout-Accuracy 3 µm at 2,5 x D. Clamping of tool shanks according to DIN 1835 A, B and DIN 6535 HB, HA.

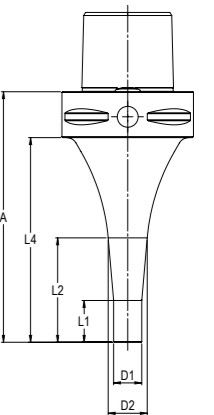

PSC 40		1 – 6 mm								
A	Part.No.	Form	L1	L2	L4	D1	D2	Balanced	kg	
75	310 1006 9C4 1	A	20	35	55	13,5	16	<1gmm	0,3	
PSC 63										
90	310 1006 9C6 1	A	20	30	68	13,5	15	20.000 G=2,5	1,0	
120	310 2006 9C6 1	A	20	50	98	13,5	19	20.000 G=2,5	1,1	



Micro ER-Chuck

Increases the access of driven tooling.
High-speed balanced. Coolant directed to cutting tool.
Compatible with common ER-nuts except ER16.
Cutting tools supported over greater length,
more rigidity and dampening.



Click

ER-Precision-Chuck, for Collet-Chucks according to DIN ISO 15488

Easy exchange of tools by using a hex-key (included in delivery).

Maintenance-free. Sealed against coolant and contamination. Slow collet taper angle.

Collet with special coating (see page 79). System-Runout-Accuracy 3 µm at 2,5 x D.

Clamping of tool shanks according to DIN 1835 A, B and DIN 6535 HB, HA.

ER 16 1 – 6 mm

A	Part.No.	L1	D1	Balanced	kg
35	310 1006 316 1*	35	13,5	by design	0,1

Special clamping nuts

Typ	Part.No.	D	L	Thread	Key
standard	138 0310 316 0	28	17,5	M22x1,5	SW 25
mini	138 0311 316 0	22	17	M19x1	E16 Zeta
internal	138 0312 316 0	M24x1	6,5	-	E16 Zeta

*only use in combination with special clamping nut, based on DIN 6499

ER 20 1 – 6 mm

A	Part.No.	L1	D1	Balanced	kg
28	310 1006 320 1	28	13,5	by design	0,1
35	310 2006 320 1	35	13,5	by design	0,1

ER 25 1 – 6 mm

A	Part.No.	L1	D1	Balanced	kg
25	310 1006 325 1	12	13,5	by design	0,1
40	310 2006 325 1	15	13,5	by design	0,1
50	310 3006 325 1	20	13,5	by design	0,1

ER 32 1 – 6 mm

A	Part.No.	L1	D1	Balanced	kg
25	310 1006 332 1	12	13,5	by design	0,2
40	310 2006 332 1	15	13,5	by design	0,2
50	310 3006 332 1	20	13,5	by design	0,2

Precision-Chuck, for Varia VX quick-change systems

One-piece for tightening from behind

VARIA VX3 1 – 6 mm

A	Part.No.	L1	L2	D1	D2	Balanced	kg
36	310 0006 VX3 1	24		13,5		by design	0,3
50	310 1006 VX3 1	12	37	13,5	18	by design	0,5

VARIA VX4 1 – 6 mm

A	Part.No.	L1	L2	D1	D2	Balanced	kg
70	310 1006 VX4 1	15	55	13,5	20	by design	1,0

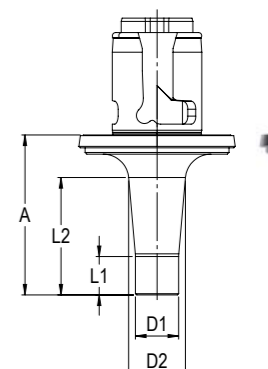
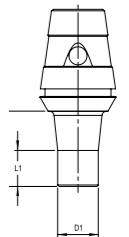

Collets and Accessories



Collets Peripheral Coolant. Additional cooling and rinsing effect. Increases the safety of processing. Special Coating. Maintenance free. Clamping of tool shanks corresponding to DIN 1835A, B and DIN 6335 HB, HA.

1 – 6 mm

D	Part.No.	Coolant	kg
1,0	136 0601 000 0	Periphery	0,02
2,0	136 0602 000 0	Periphery	0,02
2,5	136 0602 500 0	Periphery	0,02
2,8	136 0602 800 0	Periphery	0,02
3,0	136 0603 000 0	Periphery	0,02
3,5	136 0603 500 0	Periphery	0,02
4,0	136 0604 000 0	Periphery	0,02
4,5	136 0604 500 0	Periphery	0,02
5,0	136 0605 000 0	Periphery	0,02
6,0	136 0606 000 0	Periphery	0,02

special size and inch diameter on request

Collets Internal Coolant. 100% leak proof up to 100 bar coolant pressure. Special Coating. Maintenance free. Clamping of tool shanks corresponding to DIN 1835A, B and DIN 6335 HB, HA.

1 – 6 mm

D	Part.No.	Coolant	kg
1,0	136 0601 000 T	Central	0,02
2,0	136 0602 000 T	Central	0,02
2,5	136 0602 500 T	Central	0,02
2,8	136 0602 800 T	Central	0,02
3,0	136 0603 000 T	Central	0,02
3,5	136 0603 500 T	Central	0,02
4,0	136 0604 000 T	Central	0,02
4,5	136 0604 500 T	Central	0,02
5,0	136 0605 000 T	Central	0,02
6,0	136 0606 000 T	Central	0,02

special size and inch diameter on request

Torque Key	Blade lenght	Part.No.
3,0 - 5,4 Nm	113	139 0005 900 0
3,0 - 5,4 Nm	160	139 0005 900 2*

* for Part.No.: 310 3006 240 1 and 310 3006 440 1

Taper Wiper	Part.No.
for Micro	139 0000 GRO 0
Replacement papers, 25 pcs.	139 0000 GRO 2

Pull Stud	Part.No.	Thread	through-hole	Angle	Neck- Ø	kg
SK30	138 0004 230 0	M12	Ø4	15°	9	0,03
BT30	138 0004 430 0	M12	Ø4	45°	8	0,04
BT40	138 0004 440 0	M16	Ø4	45°	10	0,04

based on DIN



XXL Chuck Extension

The extension for all Albrecht chucks. Slim and long. The solution for all difficult to access processing zones. Safe transmission of clamping force and torque. For drilling, tapping, sinking, reaming, etc. Internal coolant supply. Run-out < 0.05 mm. Drilled through for coolant supply. Can be shortened individually.



Cylindrical shank 12 mm 3 – 6 mm

L	Part.No.	Coolant	D	kg
150	340 0615 812 0	Central	12	0,10
250	340 0625 812 0	Central	12	0,17
355	340 0635 812 0	Central	12	0,24

Cylindrical shank 16 mm 6 – 8 mm

L	Part.No.	Coolant	D	kg
150	340 0815 816 0	Central	16	0,15
250	340 0825 816 0	Central	16	0,28
350	340 0835 816 0	Central	16	0,40

Cylindrical shank 18 mm 8 – 10 mm

L	Part.No.	Coolant	D	kg
150	340 1015 818 0	Central	18	0,19
250	340 1025 818 0	Central	18	0,36
350	340 1035 818 0	Central	18	0,53

Cylindrical shank 20 mm 11 – 12 mm

L	Part.No.	Coolant	D	kg
150	340 1215 820 0	Central	20	0,27
250	340 1225 820 0	Central	20	0,50
350	340 1235 820 0	Central	20	0,73

Collets

For Cylindrical shank 12 mm 3 – 6 mm

D	Part.No.	AF	kg
3	146 1203 000 0	9	0,02
4	146 1204 000 0	9	0,02
5	146 1205 000 0	9	0,02
6	146 1206 000 0	9	0,02

For Cylindrical shank 16 mm 6 – 8 mm

D	Part.No.	AF	kg
6	146 1606 000 0	12	0,02
7	146 1607 000 0	12	0,02
8	146 1608 000 0	12	0,02

For Cylindrical shank 18 mm 8 – 10 mm

D	Part.No.	AF	kg
8	146 1808 000 0	14	0,04
9	146 1809 000 0	14	0,04
10	146 1810 000 0	14	0,04

For Cylindrical shank 20 mm 11 – 12 mm

D	Part.No.	AF	kg
11	146 2011 000 0	16	0,05
12	146 2012 000 0	16	0,05

special size and sealed for tools with internal coolant supply on request

Accessories

XXL-Wrench

For Cylindrical shank	Part.No.
10-50 Nm for Adapter 1/2"	149 0000 934 0*

Adapter 1/2"

for Cylindrical shank	Part.No.	AF
12	149 0001 934 1	9
16	149 0001 934 2	12
18	149 0001 934 3	14
20	149 0001 934 5	16

*only to use in combination with XXL-Extensions



APC Tool-Grinding- Toolholder



Precision-Tool-Grinding-Toolholder APC

Universal use for grinding and regrinding of tools. Manual gear transmission. Various collets within the range of 2 to 20 mm. Maximum clearance for grinding wheel. Hardened surfaces, therefore less wear-out. Maintenance-free. Quick tool and diameter exchange. Low risk of injury during tool-exchange. Positive dampening feature. Solid front part of chuck.

Advantages over Hydraulic-Chucks:

- > maintenance free due to mechanical gear transmission
- > almost no wear-out due to hardened surfaces
- > Grinding into the front part of chuck does not cause hydraulic-oil leakage
- > Operation with T-handle key under 90°
- > Higher gripping forces

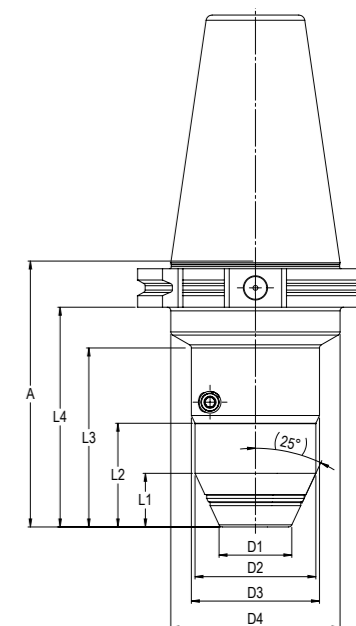

Precision Chuck APC, ISO 7388-1 (DIN 69871)

Easy exchange of tools by using a hex-key (see page 85). Maintenance-free. Sealed against coolant and particles. Slow collet taper angle. Collet with special coating (see page 84-85). System-Runout-Accuracy 3 µm at 2,5 x D. Clamping of tool shanks according to DIN 1835 A, B and DIN 6535 HB, HA.

APC 14

SK50

2-14 mm

A	Part.No.	Form	L1	L2	L3	L4	D1	D2	D3	D4	kg
80	300 114Z 251 0	A/AD	11	28	43	61	30	50	53		3,3
108	300 414Z 251 0	A/AD	38	56	71	89	24	30	50	53	3,4



APC 20

SK50

2-20 mm

A	Part.No.	Form	L1	L2	L3	L4	D1	D2	D3	D4	kg
80	300 320Z 251 0	A/AD		22	43	61	29	50	53		3,4
108	300 420Z 251 0	A/AD	44	54	71	89	32	39	50	53	3,5
110	300 320Z 250 1	A/AD	22	43	75	91	29	50	53	70	3,9



Collets

Special coating. Maintenance-free. Fine adjustable length stop.
Clamping of tool shanks according to DIN 1835 A, B and DIN 6535 HB, HA.

Collet flat



included length stop

Collet conical



included length stop

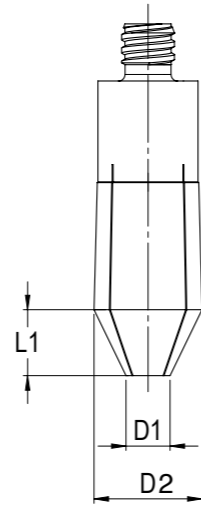

APC20

D	Part.No.	L1	Part.No.	D2	D1	L1
2,0	136 2002 000 0	0				
3,0	136 2003 000 0	0	136 2003 000 K	24,6	5,0	7,5
4,0	136 2004 000 0	0	136 2004 000 K	24,6	6,0	7,5
5,0	136 2005 000 0	0	136 2005 000 K	24,6	7,5	7,5
6,0	136 2006 000 0	0	136 2006 000 K	24,6	8,5	7,5
7,0	136 2007 000 0	0				
8,0	136 2008 000 0	0	136 2008 000 K	24,6	10,0	15,0
9,0	136 2009 000 0	0				
10,0	136 2010 000 0	0				
11,0	136 2011 000 0	0				
12,0	136 2012 000 0	0				
13,0	136 2013 000 0	0				
14,0	136 2014 000 0	0				
15,0	136 2015 000 0	0				
16,0	136 2016 000 0	0				
17,0	136 2017 000 0	0				
18,0	136 2018 000 0	0				
20,0	136 2020 000 0	0				

special size and inch diameter on request

APC14

D	Part.No.	L1
2,0	136 1402 000 0	0
3,0	136 1403 000 0	0
4,0	136 1404 000 0	0
5,0	136 1405 000 0	0
6,0	136 1406 000 0	0
7,0	136 1407 000 0	0
8,0	136 1408 000 0	0
9,0	136 1409 000 0	0
10,0	136 1410 000 0	0
11,0	136 1411 000 0	0
12,0	136 1412 000 0	0
14,0	136 1414 000 0	0

special size and inch diameter on request



Accessories

Standard Key

With marking approx. 6,5 Nm

Part.No.

139 0000 901 W



Taper Wiper

for APC 14

for APC 20

Part.No.

139 0000 GR1 0

139 0000 GR2 0



**Simply turn - ready. With more
precision into a new quality.**

**Running accuracy of 30 μm
from 1 to 16 mm.**

100% clamping force.

\varnothing 50 mm and built for ever.

Albrecht

CNC-Drill-Chucks



An Albrecht CNC chuck saves you many working days year by year.*

* see page 95

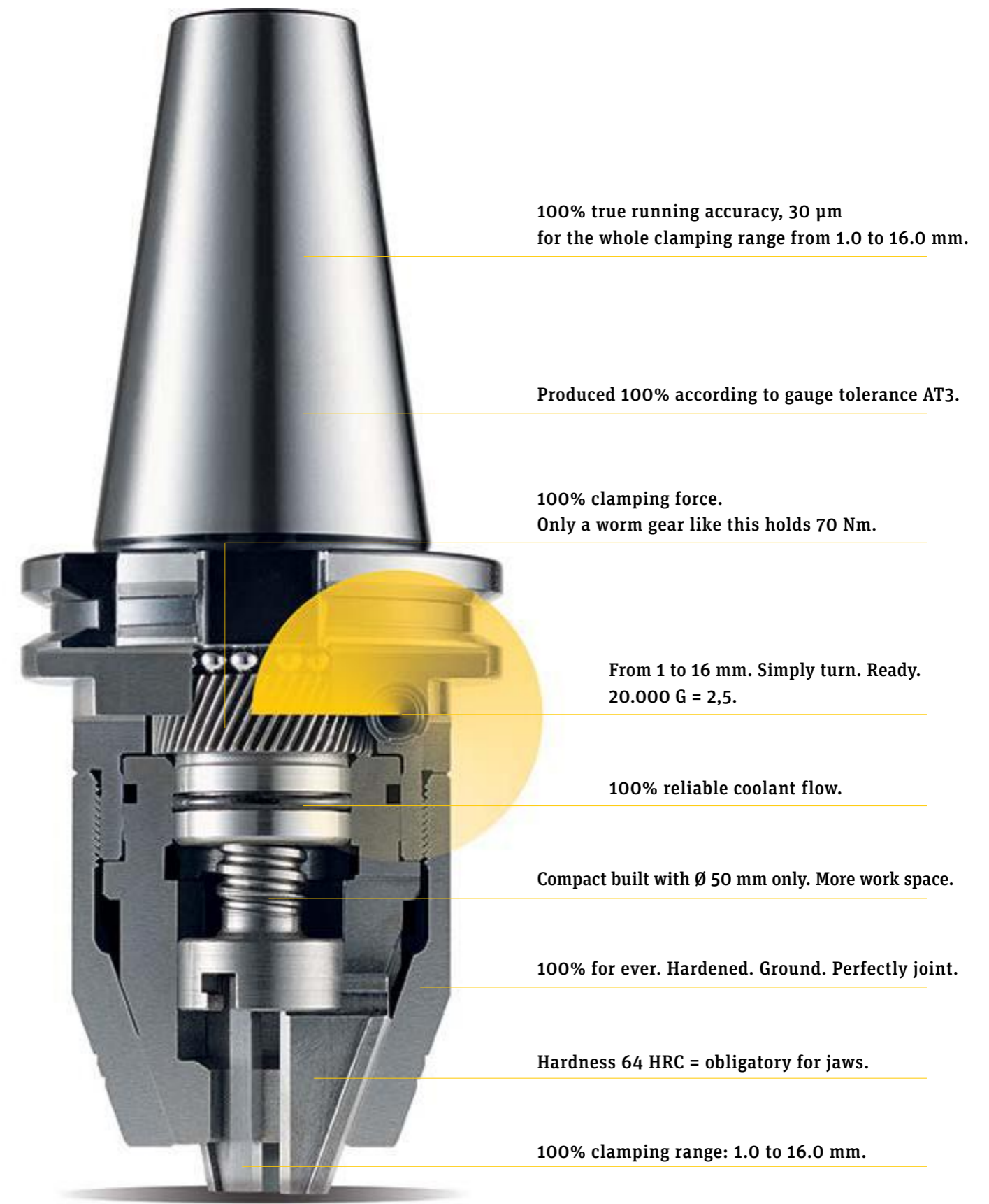

CNC Drill Chuck

Easy exchange of tools by setting of included hex-key. Highset clamping force by worm gear with high gear ratio. System-Runout-Accuracy 30 µm over the complete clamping range from 1,0 to 16 mm. Clamping cylindrical shanks according to DIN 1835 A. For drilling, countersinking, reaming, threading and for finishing. All significant parts are hardened and ground. Made in gauge tolerance AT3.

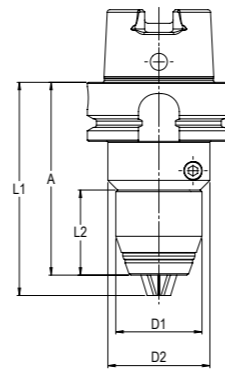

SK

1–16 mm

	A	Form	Part.No	L1	L2	D1	D2	Balanced	kg
DIN 2080-A40	73	A	800 1160 140 0	85	-	50	-	20.000 G=2,5	1,44
DIN 2080-A50	77	A	on request	85	-	50	-	20.000 G=2,5	3,44



0,5–10 mm

	A	Form	Part.No	L1	L2	D1	D2	Balanced	kg
DIN 69871-AD30	69	A/AD	800 110Z 230 0	78	37,5	38	45	20.000 G=2,5	0,70
DIN 69871-AD40	69	A/AD	800 110Z 240 0	78	37,5	38	45	20.000 G=2,5	1,15

corresponding ISO 7388-1



1–16 mm

	A	Form	Part.No	L1	L2	D1	D2	Balanced	kg
DIN 69871-AD40	80	A/AD	800 116Z 240 0	92	-	50	-	20.000 G=2,5	1,46
DIN 69871-AD50	80	A/AD	800 116Z 250 0	92	-	50	-	20.000 G=2,5	3,36

corresponding ISO 7388-1



HSK

0,5–10 mm

	A	Form	Part.No	L1	L2	D1	D2	Balanced	kg
DIN 69893 HSK 50 A	94	A	800 110Z 650 0	103	38	38	45	20.000 G=2,5	0,91
DIN 69893 HSK 63 A	85	A	800 110Z 663 0	94	38	38	45	20.000 G=2,5	1,08

coolant tubes see page 99



1–16 mm

	A	Form	Part.No	L1	L2	D1	D2	Balanced	kg
DIN 69893 HSK 50 A	107	A	800 116Z 650 0	119	-	50	-	20.000 G=2,5	1,27
DIN 69893 HSK 63 A	98	A	800 116Z 663 0	110	-	50	-	20.000 G=2,5	1,46
DIN 69893 HSK 63 F	98	A	800 116F 663 0	110	-	50	-	20.000 G=2,5	1,47
DIN 69893 HSK 80 A	101	A	800 116Z 680 0	116	-	50	-	20.000 G=2,5	2,20
DIN 69893 HSK 100 A	104	A	800 116Z 610 0	116	-	50	-	20.000 G=2,5	2,91

coolant tubes see page 99



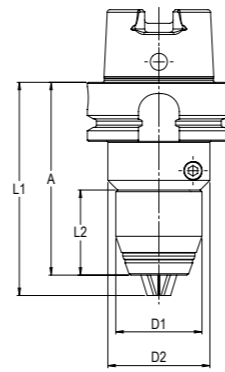

Polygon

1 – 16 mm

	A	Form	Part.No	L1	L2	D1	D2	Balanced	kg
C6/ ISO 26623-1	85	A	800 116Z 9C6 0	97	-	50	-	20.000 G=2,5	1,46
C8/ ISO 26623-1	95	A	800 116Z 9C8 0	107	-	50	-	20.000 G=2,5	2,80

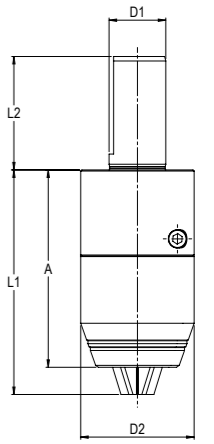

Morse

1 – 16 mm

	A	Form	Part.No	L1	L2	D1	D2	Balanced	kg
DIN 228-MK3	87	-	800 1160 MK3 0	99	-	50	-	-	1,28



MAS-BT

0,5 – 10 mm

	A	Form	Part.No	L1	L2	D1	D2	Balanced	kg
BT30 AD	72	A/AD	800 110Z 430 0	81	38	38	45	20.000 G=2,5	0,71
BT40 AD	77	A/AD	800 110Z 440 0	86	38	38	45	20.000 G=2,5	1,34

corresponding ISO 7388-2 (JIS B 6339)



Cylindrical

1 – 16 mm

	A	Form	Part.No	L1	L2	D1	D2	Balanced	kg
Cylindrical Shank	87	Central	800 116Z 825 0	99	50	25	50	-	1,24



1 – 16 mm

	A	Form	Part.No	L1	L2	D1	D2	Balanced	kg
BT40 AD	88	A/AD	800 116Z 440 0	100	-	50	-	20.000 G=2,5	1,62
BT50 AD	99	A/AD	800 116Z 450 0	111	-	50	-	20.000 G=2,5	3,47

corresponding ISO 7388-2 (JIS B 6339)



VDI

1 – 16 mm

	A	Form	Part.No	L1	L2	D1	D2	Balanced	kg
DIN 69880-30	87	Central	800 116Z 730 0	99	55	30	50	-	1,78
DIN 69880-40	87	Central	800 116Z 740 0	99	63	40	50	-	2,55



Conclusion:
7.5 m* daily add up
to 4.2 days a year you
Save. In addition a
much higher quality.

*** 7.5 minutes daily = 4.2 days per year. How we calculate this.**
Aside from the increase in quality of your work.

Using collets:

1. Loosening of nut. 2. pull out tool. 3. press collet from sleeve nut. 4. clean collet, sleeve nut and inner cone.
5. Press collet into sleeve nut. 6. Screw sleeve nut with collet onto the clamping chuck.
7. Insert tool. 8. Clamp sleeve nut with key. = 60 seconds

With an Albrecht CNC chuck

1. key unlocks. 2. pull out tool. 7. insert tool. 1. key locks. = 15 seconds

Time advantage Albrecht CNC chuck + 45 seconds

10 tool changes per day - time advantage + 450 seconds

450 seconds = 7.5 m daily x 250 working days = 1.875 m : 60 = 31.25 h : 7.5 h a day = 4.17 days



Albrecht Balancing Screws High-End for your Toolholders

Balancing Screws- Set, inclusive case, key, difference-table and 200 pieces of fine-balancing-screws

Universal use, suitable for all brands. 10 different screws in fine graduation. 20 screws of each size and Torx key. Different colours for visual identification. Precise balancing together with the clamped tool. Easy handling with Torx. Supplied with Torx ISR15 screwdriver. No need for screw locking. The balancing machine calculates automatically position and weight. Suitable for multiple uses.

Fine balancing of toolholders:

- > together with the clamped tool
- > added Chip
- > operating conditions, especially with high rpm



Typ	Part.No.
M6x4,0-8,0	139 4006 000 0

Balancing Screws

Typ	Gram	Part.No.	Amount	Colour
M6x4,0	0,43	139 4006 040 0	20	black
M6x4,5	0,52	139 4006 045 0	20	silver
M6x5,0	0,60	139 4006 050 0	20	red
M6x5,2	0,67	139 4006 052 0	20	yellow
M6x5,7	0,73	139 4006 057 0	20	silver
M6x6,0	0,77	139 4006 060 0	20	black
M6x6,5	0,86	139 4006 065 0	20	silver
M6x7,0	0,93	139 4006 070 0	20	red
M6x7,2	1,03	139 4006 072 0	20	yellow
M6x8,0	1,09	139 4006 080 0	20	black

Mountingsystem

flexible, vertical/horizontal, locked



Mounting System Base Unit	Part.No.
	730 1000 000 0



Adapters	Part.No.
ISO 7388-1 + ISO7388-2	
SK30 + BT30	730 1000 230 0
SK40 + BT40 + CAT40	730 1000 240 0
SK50 + BT50 + CAT50	730 1000 250 0
DIN 69893	
HSK50 Form A+C	730 1000 650 0
HSK63 Form A+C	730 1000 663 0
HSK80 Form A+C	730 1000 680 0
HSK100 Form A+C	730 1000 610 0
ISO 26623-1	
PSC50	730 1000 9C5 0
PSC63	730 1000 9C6 0
PSC80	730 1000 9C8 0

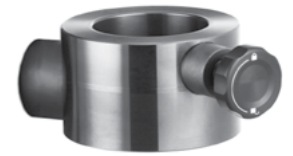

Accessories HSK

Coolant tubes DIN 69893 (HSK)	Part.No
Coolant tubes HSK-A50	139 0002 650 0
Coolant tubes HSK-A63	139 0002 663 0
Coolant tubes HSK-A80	139 0002 680 0
Coolant tubes HSK-A100	139 0002 610 0



Key with T-handle	Part.No
for coolant tubes HSK-A50	139 0020 650 0
for coolant tubes HSK-A63	139 0020 663 0
for coolant tubes HSK-A80	139 0020 680 0
for coolant tubes HSK-A100	139 0020 610 0



Handling APC and Ultra

The Albrecht chuck is high precision toolholder with clamping gear. Its unique design provides a very high clamping force, run-out accuracy as well as a positive dampening feature for machining (milling, drilling, reaming, tapping, heavy-duty cutting, finish milling, HSC operations). The Chuck uses a special collet to clamp the cutting tool and is operated by a hex key on the periphery.

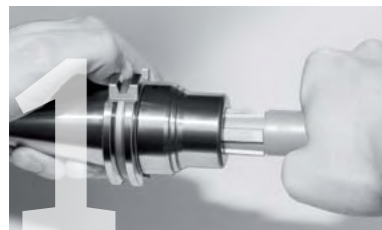

Cleaning, insert the Collet

Before each use, clean the inner cone chuck free cloth and chuck cone cleaner. Attention, do not work with compressed air during the cleaning process, as otherwise dissolved dirt particles can get into parts of the gearbox.



For maximum clamping forces, the bore, the tool shank, the cone of the clamping sleeve and the inner cone chuck must be degreased each time the tool is changed.



Insert the cleaned and undamaged tool shank into the clamping sleeve, observing the minimum clamping depth, see page 101. Screw the clamping sleeve with tool into the chuck manually until the clamping sleeve touches the cone.



Clamping

The chucking procedure starts by engaging the screw on the side of the chuck and rotating the hex key clockwise. Max. clamping torque see product-marking. Put in the hex key as far as possible. Hex tool surface is to be inspected about damages!



Match the two arrowheads when clamping.



Releasing

Open the Chuck by turning the hex key counter-clockwise. Note: when opening the chuck you must overcome two resistance points. First, you will overcome the friction torque and then the collet is loosened. Then open until the tool can be taken out, respectively the collet can be unscrewed manually.



Length adjustment

A length stop screw is located in the collet and can be adjusted with a hex key. For operation from the back through the chuck with taper shank a bolt with a through hole is necessary (form AD). The range of the length adjustment is 11mm.

Technical Data Type	Clamping-Diameter, Ø mm / Ø Zoll		Min. Clamping Depth	Max. Clamping Depth
14/20	2 - 5	1/8" - 3/16"	17	66
	6	1/4"	22	40
	7 - 10	5/16" - 3/8"	30	50
	11 - 15	7/16" - 9/16"	38	50
20	16 - 20	5/8" - 3/4"	38	48,5
25	12,7	1/2"	47	54,5
	16 - 32	5/8" - 11/4"	47	60

Balancing grade

Each Albrecht Chuck is fine-balanced without collet and tool according to the laser marking. Higher balancing quality and rpm on request. The use of shanks with slots influences the balancing grade and run-out accuracy of the whole system.

Fine balancing with balancing-screws

Some of the APCs and all Ultra-Chucks are equipped with balancing threads and are thus capable of being balanced. By using fine balance screws, an even higher overall balancing quality can be achieved. The balancing screws must be tightened hand tight to the thread base according to the recommended weight and thread position of the balancing machine. Several screws can be screwed in one bore. An additional screw locking is not necessary. Make sure that the screws do not protrude beyond the interference contour.

The max. operating speed is not affected by the use of fine balance screws. Recommendation: Albrecht M6 Balancing-set, Art. No.: 139 4006 000 0 (see page 96).

Maintenance

The Chuck is maintenance free over his lifetime. Clean chuck (especially the inner cone) and collet including thread after usage with a solvent base cleaner. According to contamination the cleaning cycles have to be adjusted. After cleaning, apply a thin coat of anticorrosive.

Repairs

In order to guarantee the precision of the tool, any chuck in need of repair has to be sent to the manufacturer or to an authorized national agent only. We recommend checking the chuck and the collet for run-out deviations and gripping torque periodic, especially after a tool break or crash.

Handling Micro

The Albrecht Micro Chuck is a high precision toolholder with an integrated clamping screw. Its unique design provides a high run-out accuracy as well as a positive dampening feature for clamping of tools with cylindrical shafts for machining (milling, finish-milling, HSC-milling, drilling, tapping, reaming). The Micro uses a special collet to clamp the cutting tool and is operated by a hex key from the behind.



Cleaning, insert the Collet

Before each use, clean the tool shaft, inner-cone of Micro and collet. To completely remove grease and dirt particles use a lint-free cloth and a cleaner. Attention, do not work with compressed air during the cleaning process, as otherwise dissolved dirt particles can get into parts of the gearbox.



For maximum clamping forces, the bore, the tool shank, the cone of the clamping sleeve and the inner cone chuck must be degreased each time the tool is changed.



Insert the cleaned and undamaged tool shank into the clamping sleeve, observing the minimum clamping depth, see page 103. Screw the clamping sleeve with tool into the chuck manually until the clamping sleeve touches the cone.



Clamping

Put in the hex key as far as possible. Hex tool surface is to be inspected for damages! The chucking procedure start with inserting the hex key from behind through the chuck and rotating the hex key clockwise. Max. clamping torque see mark on the Micro. Use only the original Albrecht clamping key which is included or the torque key, 3,0 - 5,4 Nm, part.no 139 0005 900 0, see page 79.



Releasing

Open the Micro by turning the hex key counter-clockwise. Note: when opening the Micro, you must overcome two resistance points. First, you will overcome the friction torque and then the collet is loosened. Then open until the tool can be taken out, or rather the collet can be unscrewed manually.

Clamping depth
depending on clamping diameter

Ø	t min	t max
2-4	18	36
5	18	28
6	26	36

Min. Clamping depth = t min
Max. Clamping depth = t max

Max. rpm see product-marking
Max. operation temperature: 110°C
Max. coolant pressure: 100 bar

Balancing grade

Each Albrecht Micro-Chuck is fine-balanced without collet and tool according to the laser marking. Higher balancing quality and rpm on request. The use of shanks with slots influences the balancing grade and run-out accuracy of the whole system.

Maintenance

The Micro-Chuck is maintenance free over his lifetime. Clean chuck (especially the inner cone) and collet including thread after usage with a solvent base cleaner. According to contamination the cleaning cycles have to be adjusted. After cleaning, apply a thin coat of anticorrosive.

Repairs

In order to guarantee the precision of the tool, any chuck in need of repair has to be sent to the manufacturer or to an authorized national agent only. We recommend checking the Micro-Chuck and the collet for run-out deviations and gripping torque periodic, especially after a tool break or crash.

Assessment of tool holder performance in roughing with end mills

Abstract

Tool holders are an important power train component of milling with shaft tools having a high impact on dynamic process behaviour and process results. This leads to a significant demand among industrial companies for scientifically proven methods to analyse tool holders which are easy to use as well. Different approaches were applied in order to meet these demands. The dynamic vibrational behaviour of different clamping mechanisms is investigated using tool holders of similar dimensions. First, the resonance frequencies of the tool holders are identified from dynamic compliance measurements in the machine tool. Subsequently, the dynamic process behaviour is investigated by peripheral milling tests in which vibrations of tool and tool holder are detected by acceleration sensors and microphones. Analysis of the sensor data and optical analysis of the manufactured surface reveal a significant influence of the particular clamping mechanism, superimposed by certain geometrical variations of the investigated tool holders. Chatter frequencies occurring during milling tests seem independent of the clamping mechanism respectively the particular tool holder and are caused by the tool or machine-tool components. They correspond roughly with the natural frequencies identified before. Chatter intensity and spindle speeds, at which chatter occurs, are influenced by the tool holders. The occurrence of chatter vibrations correlates with a significant drop in the surface quality of the workpiece. High resonance frequencies of the tool holder excited by chatter and low-frequency waviness observed on the machined surface are related. The well-known phenomenon can be explained under rough milling conditions by a 2D-model-based superposition of subsequent cutting edge engagements. This in turn may enable dynamic analysis and optimisation of rough milling operations by easy to use shop floor equipment in future.

Keywords Tool holders · Dynamic behaviour · Surface formation · Frequency analysis · Shaft tools · Steel milling

Investigated tool holder systems:

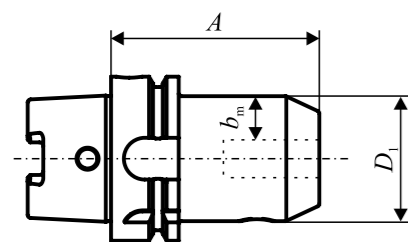

Fig. 1 Examples of the investigated tool holder systems

Test setup:

Machine: MC12 by Gebr. Heller
 Tool: torus cutter, D=12, number of teeth=4
 Material: Steel, 42CrMo4 (1.7225)
 Cutting Parameter:
 n= 3979 rev/min
 fz= 0,04 mm/rev/tooth
 ae= 7mm
 ap= 18mm

Table 1 Main properties of the investigated tool holders



Tool holder	A [mm]	mass m [g]	D ₁ [mm]	b _m [mm]	Design
APC	92	1457	40	18	Modular
ER	100	1274	42	12.5	Modular
HE	90	1123	32	9	Monolithic ^a
TS	90	918	24	8	Monolithic ^a
Weldon	80	1120	42	15	Monolithic ^b

^aFull-periphery clamping

^bPoint-line clamping

Correlation between in-process vibrations and surface quality:

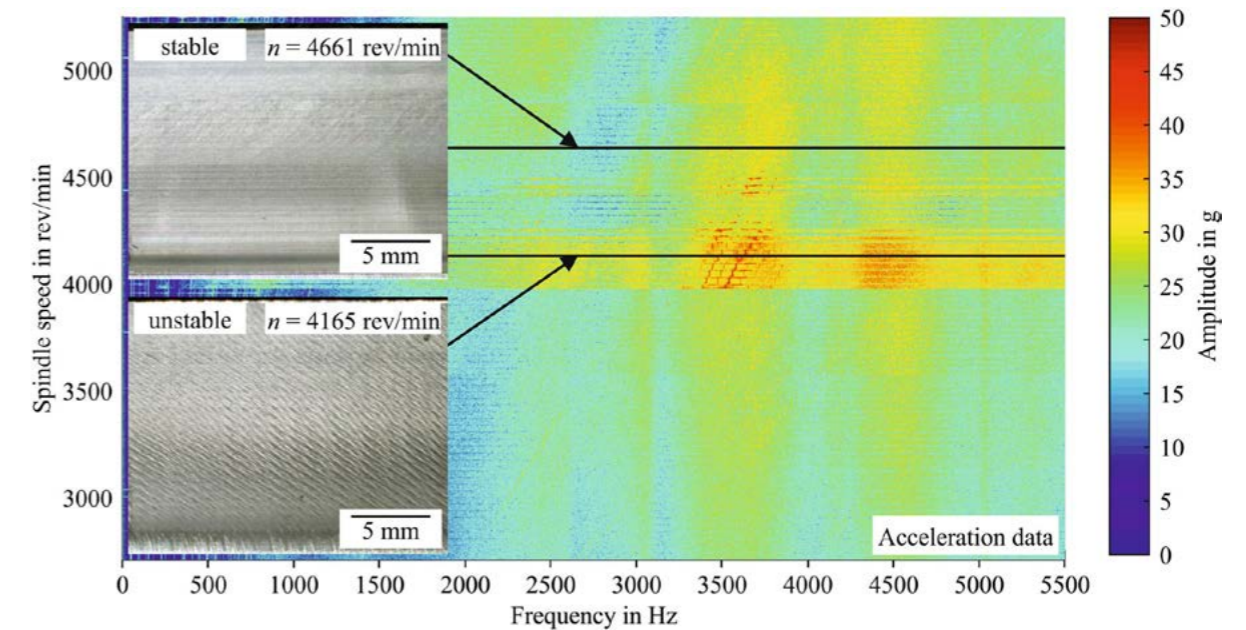

Fig. 7 Correlation between in-process vibrations and surface quality. (Tool holder: ER-collet, n = 2708 – 5250 rev/min, f_z = 0.04 mm/rev/tooth, a_c = 7 mm, a_p = 18 mm)

APC with best results in comparison to other tool-holders:

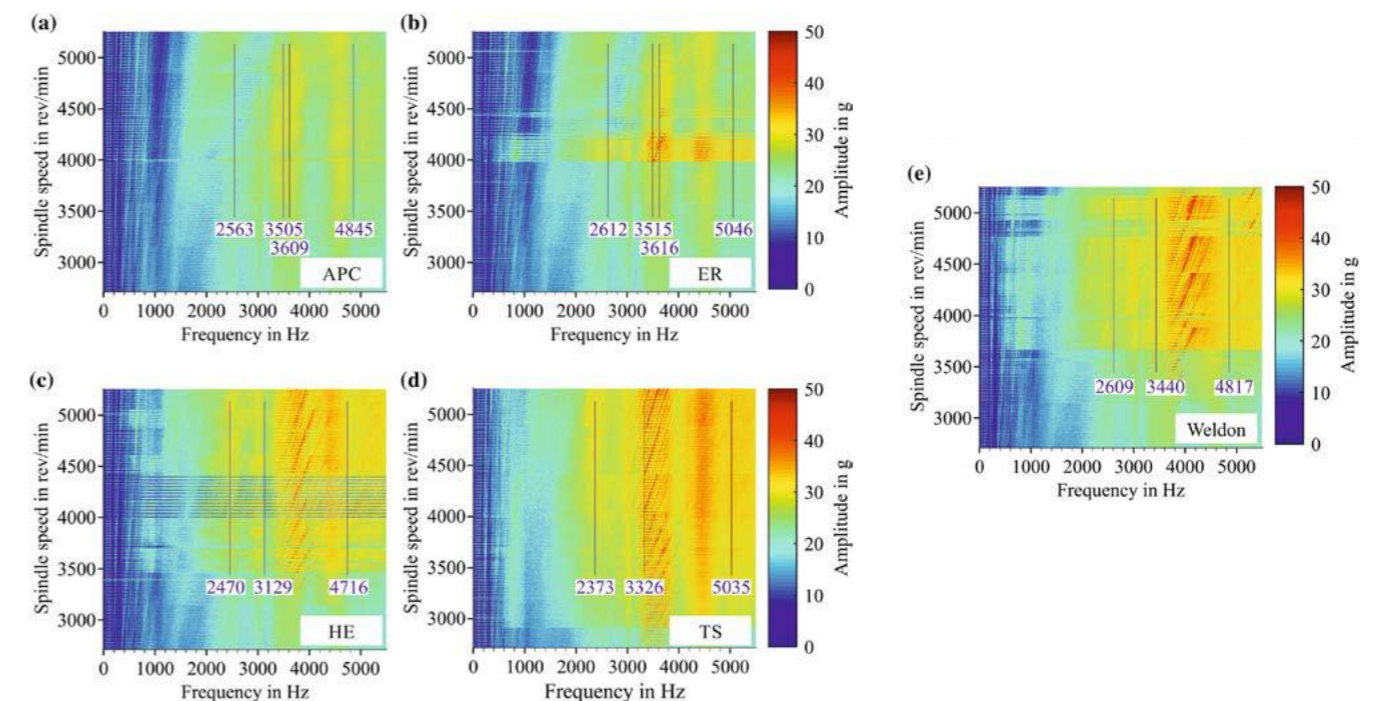

Fig. 6 Visualisation of in-process vibrations using Campbell diagrams based on acceleration sensor data. (n = 2708 – 5250 rev/min, f_z = 0.04 mm/rev/tooth, a_c = 7 mm, a_p = 18 mm)



We reserve the right for changes in design due to technical improvements. Pictures and dimensions not binding.

Albrecht Germany
Version 6 9/2024

ALBRECHT
PRÄZISION
GmbH & Co. KG

D-73249 Wernau
Antoniusstraße 25
T +49 7153 / 3006-0
F +49 7153 / 300611
info@albrecht-germany.com
www.albrecht-germany.com

ALBRECHT
Precision Chucks